



Issue 1



Multifunction Meters

Transducers & Isolators

Temperature Controllers

Converters & Recorders

Digital Panel Meters

Current Transformers

Analogue Panel Meters

Shunts

Digital Multimeters

Clamp Meters

Insulation Testers

Operating Manual

EM DC 6001-6002 COMPACT DC ENERGY METER

SUBJECT TO CHANGE WITHOUT NOTICE

This manual superseded all previous versions – please keep for future reference

DIGITAL MULTIFUNCTION INSTRUMENT

Programmable Multi-function DC Energy Meter

Installation & Operating Instructions

Section	Contents
1	Introduction
2	Communication Parameter selection screen
3	RS 485 (ModBus) <ul style="list-style-type: none">3.1 Accessing 3X and 4X registers for Reading Measured values3.2 Accessing 4X register for Reading & Writing Settings3.3 User Assignable Modbus Registers
4	Datalogging <ul style="list-style-type: none">4.1 Event Datalogging4.2 Time Datalogging4.3 Load Profile Datalogging
5	Connection for RS 485

1. Introduction

The Multifunction DC Energy Meter is a panel mounted 96 x 96mm DIN Quadratic Digital Panel Meter, which measures important electrical parameters in DC Network and replaces the multiple analog panel meters. It measures important electrical parameters like DC voltage, Current, Power, Energy(Import & Export), Demand & many more. The meter can be used for upto 4 channels. It integrates accurate measurement technology with bright LED display (8 digit x 4). The meter can be configured on site for various parameters including Nominal Voltage, Current Full Scale, Current Shunt, No. of channels, Demand Integration Time etc. The front panel has three push buttons using which the user can scroll through different screens & configure the product. It also includes 20 LEDs which in conjunction with LED display, provides information in different units and gives overview of channel status.

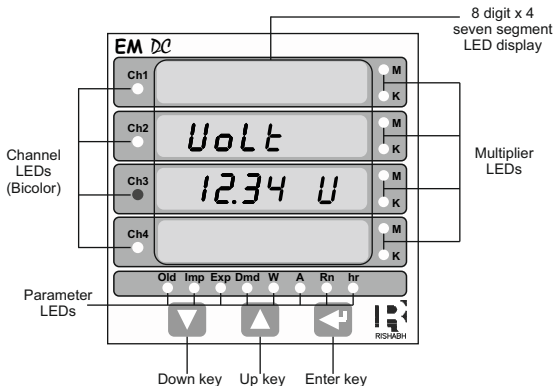

Operation via standard Rs485 is also possible. Through this optional interface all the above mentioned parameters can be configured and programmed. For modbus service, it is essential that device address, baud rate and parity should be configured properly. This document specifies only the interface between a Master device and Energy Meter for electrical variable through MODBUS over RS485.

2. Communication Parameter Selection Screen

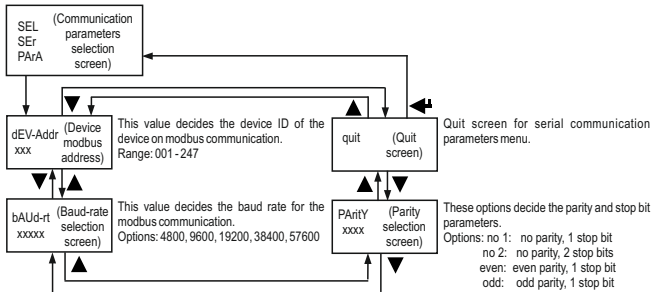

The parameter values set here are only applicable for modbus communication. While using the USB port on the meter these values are as following and non-editable.

Device address: 1
Baud Rate: 57600
Parity: No
Stop bits: 1

Parameter Editing Guide

Use these points to change any value in setup screens.

- 1) Use **◀** key to enter editing mode. A blinking decimal point will be displayed as cursor.
- 2) Use **▲** & **▼** keys to increase or decrease the digit values respectively, or cycle through options.
- 3) Use **▶** key to go to the next cursor position.
- 4) Use **◀** key to confirm the value and finish editing.
- 5) Longpress **▲** & **▼** together to go to the previous menu.
The same can be achieved by going to quit screen and pressing **◀** key.
- 6) If user inputs values out of the limits specified, they are brought to the limit values automatically by the meter and showed at value confirmation.
- 7) Number of 'x's denote displayed digits on the screen which the user can edit.

3. RS 485 (ModBus) Output :

THE MULTIFUNCTION DC ENERGY METER supports MODBUS (RS485) RTU protocol(2-wire) .

Connection should be made using twisted pair shielded cable. All "A" and "B" connections are daisy chained together. The screens should also be connected to the "Gnd" terminal. To avoid the possibility of loop currents, an Earth connection should be made at one point on the network. Loop (ring) topology does not require any termination load. Line topology may or may not require terminating loads depending on the type and length of cable used. The impedance of the termination load should match the impedance of the cable and be at both ends of the line. The cable should be terminated at each end with a 120 ohm (1/4 Watt min.) resistor.

RS 485 network supports maximum length of 1.2km. Including the Master, a maximum of 32 instruments can be connected in RS485 network. The permissible address range for The Meter is between 1 and 247 for 32 instruments. Broadcast Mode (address 0) is not allowed. The maximum latency time of an Meter is 200ms i.e. this is the amount of time that can pass before the first response character is output.

After sending any query through software (of the Master), it must allow 200ms of time to elapse before assuming that the Meter is not going to respond. If slave does not respond within 200 ms, Master can ignore the previous query and can issue fresh query to the slave.

The each byte in RTU mode has following format:

	8-bit binary, hexadecimal 0-9, A-F 2 hexadecimal characters contained in each 8-bit field of the message
Format of Data Bytes	4 bytes (32 bits) per parameter. Floating point format (to IEEE 754) Most significant byte first (Alternative least significant byte first)
Error Checking Bytes	2 byte Cyclical Redundancy Check (CRC)
Byte format	1 start bit, 8 data bits, least significant bit sent first 1 bit for even/odd parity 1 stop bit if parity is used; 1 or 2 bits if no parity

Baud Rate is user selectable from the front panel between 4800, 9600, 19200, 38400 & 57600 bps.

Function code :

03	Read Holding Registers	Read content of read / write location (4X)
04	Read input Registers	Read content of read only location (3X)
16	Presets Multiple Registers	Set the content of read / write locations (4X)

Exception Cases : An exception code will be generated when Meter receives ModBus query with valid parity & error check but which contains some other error (e.g. Attempt to set floating point variable to an invalid value) The response generated will be "Function code" ORed with HEX (80H). The exception codes are listed below

01	Illegal function	The function code is not supported by Meter
02	Illegal Data Address	Attempt to access an invalid address or an attempt to read or write part of a floating point value
03	Illegal DataValue	Attempt to set a floating point variable to an invalid value

3.1 Accessing 3X and 4X register for reading measured values:

Two consecutive 16 bit registers represent one parameter. Refer **TABLE 1** for the addresses of 3X and 4X registers used for parameters measured by the instrument. Each parameter is held in the 3X as well as 4X registers. Modbus Code 04 and 03 are used to access all parameters in 3X and 4X registers respectively.

Example :

To read parameter,

Current Ch2 from 3X: Start address= 00 04 Number of registers = 02

Power Ch1 from 4X: Start address= 10 0A Number of registers = 02

Note : Number of registers = Number of parameters x 2

Each Query for reading the data must be restricted to 40 parameters or less. Exceeding the 40 parameter limit will cause a ModBus exception code to be returned.

Query for 3X read:

01 (Hex)	04 (Hex)	00 (Hex)	04(Hex)	00 (Hex)	02(Hex)	30 (Hex)	0A (Hex)
Device Address	Function Code	Start Address High	Start Address Low	Number of Registers Hi	Number of Registers Lo	CRC Low	CRC High

3X Response: Current Ch2 (219.254 A)

01 (Hex)	04 (Hex)	04 (Hex)	43 (Hex)	5B (Hex)	41 (Hex)	21 (Hex)	6F (Hex)	9B (Hex)
Device Address	Function Code	Byte Count	Data Register1 High Byte	Data Register1 Low Byte	Data Register2 High Byte	Data Register2 Low Byte	CRC Low	CRC High

Byte Count : Total number of data bytes received.

Query for 4X read:

01 (Hex)	03 (Hex)	10 (Hex)	0A(Hex)	00 (Hex)	02(Hex)	E0 (Hex)	C9 (Hex)
Device Address	Function Code	Start Address High	Start Address Low	Number of Registers Hi	Number of Registers Lo	CRC Low	CRC High

4X Response: Power Ch1 (2000 W)

01 (Hex)	03 (Hex)	04 (Hex)	44 (Hex)	FA (Hex)	00 (Hex)	00 (Hex)	CE (Hex)	F2 (Hex)
Device Address	Function Code	Byte Count	Data Register1 High Byte	Data Register1 Low Byte	Data Register2 High Byte	Data Register2 Low Byte	CRC Low	CRC High

Start Address High : Most significant 8 bits of starting address of the parameter requested.

Start Address low : Least significant 8 bits of starting address of the parameter requested.

Number of register Hi : Most significant 8 bits of Number of registers requested.

Number of register Lo : Least significant 8 bits of Number of registers requested.

Data register 1 High Byte : Most significant 8 bits of Data register 1 of the parameter requested.

Data register 1 Low Byte : Least significant 8 bits of Data register 1 of the parameter requested.

Data register 2 High Byte : Most significant 8 bits of Data register 2 of the parameter requested.

Data register 2 Low Byte : Least significant 8 bits of Data register 2 of the parameter requested.

(Note : Two consecutive 16 bit register represent one parameter.)

TABLE 1 : 3X and 4X register addresses for measured parameters

Address (3X)	Address (4X)	Parameter Number	Parameter	Start Address Hex 3X		Start Address Hex 4X	
				High Byte	Low Byte	High Byte	Low Byte
30001	44097	0	Voltage	00	00	10	00
30003	44099	1	Current Ch1	00	02	10	02
30005	44101	2	Current Ch2	00	04	10	04
30007	44103	3	Current Ch3	00	06	10	06
30009	44105	4	Current Ch4	00	08	10	08
30011	44107	5	Power Ch1	00	0A	10	0A
30013	44109	6	Power Ch2	00	0C	10	0C
30015	44111	7	Power Ch3	00	0E	10	0E
30017	44113	8	Power Ch4	00	10	10	10
30019	44115	9	Total Import Power	00	12	10	12
30021	44117	10	Total export Power	00	14	10	14
30023	44119	11	Energy Imp Ch1	00	16	10	16
30025	44121	12	Energy Imp Ch2	00	18	10	18
30027	44123	13	Energy Imp Ch3	00	1A	10	1A
30029	44125	14	Energy Imp Ch4	00	1C	10	1C
30031	44127	15	Energy Exp Ch1	00	1E	10	1E
30033	44129	16	Energy Exp Ch2	00	20	10	20
30035	44131	17	Energy Exp Ch3	00	22	10	22
30037	44133	18	Energy Exp Ch4	00	24	10	24
30039	44135	19	Total Import Energy	00	26	10	26
30041	44137	20	Total Export Energy	00	28	10	28
30059	44155	29	Amp Hour Imp Ch1	00	3A	10	3A
30061	44157	30	Amp Hour Imp Ch2	00	3C	10	3C

TABLE 1 : Continued...

Address (3X)	Address (4X)	Parameter Number	Parameter	Start Address Hex 3X		Start Address Hex 4X	
				High Byte	Low Byte	High Byte	Low Byte
30063	44159	31	Amp Hour Imp Ch3	00	3E	10	3E
30065	44161	32	Amp Hour Imp Ch4	00	40	10	40
30067	44163	33	Amp Hour Exp Ch1	00	42	10	42
30069	44165	34	Amp Hour Exp Ch2	00	44	10	44
30071	44167	35	Amp Hour Exp Ch3	00	46	10	46
30073	44169	36	Amp Hour Exp Ch4	00	48	10	48
30075	44171	37	Total Import AH	00	4A	10	4A
30077	44173	38	Total Export AH	00	4C	10	4C
30079	44175	39	Import Power Demand Ch1	00	4E	10	4E
30081	44177	40	Import Power Demand Ch2	00	50	10	50
30083	44179	41	Import Power Demand Ch3	00	52	10	52
30085	44181	42	Import Power Demand Ch4	00	54	10	54
30087	44183	43	Export Power Demand Ch1	00	56	10	56
30089	44185	44	Export Power Demand Ch2	00	58	10	58
30091	44187	45	Export Power Demand Ch3	00	5A	10	5A
30093	44189	46	Export Power Demand Ch4	00	5C	10	5C
30095	44191	47	Total Import Power Demand	00	5E	10	5E
30097	44193	48	Total Export Power Demand	00	60	10	60
30099	44195	49	Import Current Demand Ch1	00	62	10	62
30101	44197	50	Import Current Demand Ch2	00	64	10	64
30103	44199	51	Import Current Demand Ch3	00	66	10	66
30105	44201	52	Import Current Demand Ch4	00	68	10	68
30107	44203	53	Export Current Demand Ch1	00	6A	10	6A
30109	44205	54	Export Current Demand Ch2	00	6C	10	6C
30111	44207	55	Export Current Demand Ch3	00	6E	10	6E
30113	44209	56	Export Current Demand Ch4	00	70	10	70

TABLE 1 : Continued...

Address (3X)	Address (4X)	Parameter Number	Parameter	Start Address Hex 3X		Start Address Hex 4X	
				High Byte	Low Byte	High Byte	Low Byte
30115	44211	57	Total Import Current Demand	00	72	10	72
30117	44213	58	Total Export Current Demand	00	74	10	74
30119	44215	59	Max Voltage	00	76	10	76
30121	44217	60	Min Voltage	00	78	10	78
30123	44219	61	Max Current Ch1	00	7A	10	7A
30125	44221	62	Max Current Ch2	00	7C	10	7C
30127	44223	63	Max Current Ch3	00	7E	10	7E
30129	44225	64	Max Current Ch4	00	80	10	80
30131	44227	65	Min Current Ch1	00	82	10	82
30133	44229	66	Min Current Ch2	00	84	10	84
30135	44231	67	Min Current Ch3	00	86	10	86
30137	44233	68	Min Current Ch4	00	88	10	88
30139	44235	69	Max Import Power Demand Ch1	00	8A	10	8A
30141	44237	70	Max Import Power Demand Ch2	00	8C	10	8C
30143	44239	71	Max Import Power Demand Ch3	00	8E	10	8E
30145	44241	72	Max Import Power Demand Ch4	00	90	10	90
30147	44243	73	Max Export Power Demand Ch1	00	92	10	92
30149	44245	74	Max Export Power Demand Ch2	00	94	10	94
30151	44247	75	Max Export Power Demand Ch3	00	96	10	96
30153	44249	76	Max Export Power Demand Ch4	00	98	10	98
30155	44251	77	Max Import Current Demand Ch1	00	9A	10	9A
30157	44253	78	Max Import Current Demand Ch2	00	9C	10	9C
30159	44255	79	Max Import Current Demand Ch3	00	9E	10	9E
30161	44257	80	Max Import Current Demand Ch4	00	A0	10	A0
30163	44259	81	Max Export Current Demand Ch1	00	A2	10	A2
30165	44261	82	Max Export Current Demand Ch2	00	A4	10	A4

TABLE 1 : Continued...

Address (3X)	Address (4X)	Parameter Number	Parameter	Start Address Hex 3X		Start Address Hex 4X	
				High Byte	Low Byte	High Byte	Low Byte
30167	44263	83	Max Export Current Demand Ch3	00	A6	10	A6
30169	44265	84	Max Export Current Demand Ch4	00	A8	10	A8
30171	44267	85	Energy Imp Ch1 on update rate	00	AA	10	AA
30173	44269	86	Energy Imp Ch2 on update rate	00	AC	10	AC
30175	44271	87	Energy Imp Ch3 on update rate	00	AE	10	AE
30177	44273	88	Energy Imp Ch4 on update rate	00	B0	10	B0
30179	44275	89	Energy Import Ch1 on update rate OF	00	B2	10	B2
30181	44277	90	Energy Import Ch2 on update rate OF	00	B4	10	B4
30183	44279	91	Energy Import Ch3 on update rate OF	00	B6	10	B6
30185	44281	92	Energy Import Ch4 on update rate OF	00	B8	10	B8
30187	44283	93	Energy Exp Ch1 on update rate	00	BA	10	BA
30189	44285	94	Energy Exp Ch2 on update rate	00	BC	10	BC
30191	44287	95	Energy Exp Ch3 on update rate	00	BE	10	BE
30193	44289	96	Energy Exp Ch4 on update rate	00	C0	10	C0
30195	44291	97	Energy Export Ch1 on update rate OF	00	C2	10	C2
30197	44293	98	Energy Export Ch2 on update rate OF	00	C4	10	C4
30199	44295	99	Energy Export Ch3 on update rate OF	00	C6	10	C6
30201	44297	100	Energy Export Ch4 on update rate OF	00	C8	10	C8
30203	44299	101	On Hour	00	CA	10	CA
30205	44301	102	Run Hour Ch1	00	CC	10	CC
30207	44303	103	Run Hour Ch2	00	CE	10	CE
30209	44305	104	Run Hour Ch3	00	D0	10	D0
30211	44307	105	Run Hour Ch4	00	D2	10	D2
30213	44309	106	No. of Interruptions	00	D4	10	D4
30215	44311	107	Old Energy Imp Ch 1	00	D6	10	D6
30217	44313	108	Old Energy Imp Ch 2	00	D8	10	D8

TABLE 1 : Continued...

Address (3X)	Address (4X)	Parameter Number	Parameter	Start Address Hex 3X		Start Address Hex 4X	
				High Byte	Low Byte	High Byte	Low Byte
30219	44315	109	Old Energy Imp Ch 3	00	DA	10	DA
30221	44317	110	Old Energy Imp Ch 4	00	DC	10	DC
30223	44319	111	Old Energy Import Ch1 OF	00	DE	10	DE
30225	44321	112	Old Energy Import Ch2 OF	00	E0	10	E0
30227	44323	113	Old Energy Import Ch3 OF	00	E2	10	E2
30229	44325	114	Old Energy Import Ch4 OF	00	E4	10	E4
30231	44327	115	Old Energy Exp Ch 1	00	E6	10	E6
30233	44329	116	Old Energy Exp Ch 2	00	E8	10	E8
30235	44331	117	Old Energy Exp Ch 3	00	EA	10	EA
30237	44333	118	Old Energy Exp Ch 4	00	EC	10	EC
30239	44335	119	Old Energy Export Ch1 OF	00	EE	10	EE
30241	44337	120	Old Energy Export Ch2 OF	00	F0	10	F0
30243	44339	121	Old Energy Export Ch3 OF	00	F2	10	F2
30245	44341	122	Old Energy Export Ch4 OF	00	F4	10	F4
30247	44343	123	Old Amp Hour Imp Ch1	00	F6	10	F6
30249	44345	124	Old Amp Hour Imp Ch2	00	F8	10	F8
30251	44347	125	Old Amp Hour Imp Ch3	00	FA	10	FA
30253	44349	126	Old Amp Hour Imp Ch4	00	FC	10	FC
30255	44351	127	Old Amp Hour Exp Ch1	00	FE	10	FE
30257	44353	128	Old Amp Hour Exp Ch2	01	00	11	00
30259	44355	129	Old Amp Hour Exp Ch3	01	02	11	02
30261	44357	130	Old Amp Hour Exp Ch4	01	04	11	04
30263	44359	131	Old Max Import Power Demand Ch1	01	06	11	06
30265	44361	132	Old Max Import Power Demand Ch2	01	08	11	08
30267	44363	133	Old Max Import Power Demand Ch3	01	0A	11	0A
30269	44365	134	Old Max Import Power Demand Ch4	01	0C	11	0C

TABLE 1 : Continued...

Address (3X)	Address (4X)	Parameter Number	Parameter	Start Address Hex 3X		Start Address Hex 4X	
				High Byte	Low Byte	High Byte	Low Byte
30271	44367	135	Old Max Export Power Demand Ch1	01	0E	11	0E
30273	44369	136	Old Max Export Power Demand Ch2	01	10	11	10
30275	44371	137	Old Max Export Power Demand Ch3	01	12	11	12
30277	44373	138	Old Max Export Power Demand Ch4	01	14	11	14
30279	44375	139	Old Max Import Current Demand Ch1	01	16	11	16
30281	44377	140	Old Max Import Current Demand Ch2	01	18	11	18
30283	44379	141	Old Max Import Current Demand Ch3	01	1A	11	1A
30285	44381	142	Old Max Import Current Demand Ch4	01	1C	11	1C
30287	44383	143	Old Max Export Current Demand Ch1	01	1E	11	1E
30289	44385	144	Old Max Export Current Demand Ch2	01	20	11	20
30291	44387	145	Old Max Export Current Demand Ch3	01	22	11	22
30293	44389	146	Old Max Export Current Demand Ch4	01	24	11	24
30295	44391	147	Old On Hour	01	26	11	26
30297	44393	148	Old Run Hour Ch1	01	28	11	28
30299	44395	149	Old Run Hour Ch2	01	2A	11	2A
30301	44397	150	Old Run Hour Ch3	01	2C	11	2C
30303	44399	151	Old Run Hour Ch4	01	2E	11	2E
30305	44401	152	Old No. of Interruptions	01	30	11	30
30307	44403	153	Energy Import Ch1 OF	01	32	11	32
30309	44405	154	Energy Import Ch2 OF	01	34	11	34
30311	44407	155	Energy Import Ch3 OF	01	36	11	36
30313	44409	156	Energy Import Ch4 OF	01	38	11	38
30315	44411	157	Energy Export Ch1 OF	01	3A	11	3A
30317	44413	158	Energy Export Ch2 OF	01	3C	11	3C
30319	44415	159	Energy Export Ch3 OF	01	3E	11	3E
30321	44417	160	Energy Export Ch4 OF	01	40	11	40

TABLE 1 : Continued...

Address (3X)	Address (4X)	Parameter Number	Parameter	Start Address Hex 3X		Start Address Hex 4X	
				High Byte	Low Byte	High Byte	Low Byte
30323	44419	161	Total Import Energy OF	01	42	11	42
30325	44421	162	Total Export Energy OF	01	44	11	44
30327	44423	163	AH Import Ch1 OF	01	46	11	46
30329	44425	164	AH Import Ch2 OF	01	48	11	48
30331	44427	165	AH Import Ch3 OF	01	4A	11	4A
30333	44429	166	AH Import Ch4 OF	01	4C	11	4C
30335	44431	167	AH Export Ch1 OF	01	4E	11	4E
30337	44433	168	AH Export Ch2 OF	01	50	11	50
30339	44435	169	AH Export Ch3 OF	01	52	11	52
30341	44437	170	AH Export Ch4 OF	01	54	11	54
30343	44439	171	Total Import AH OF	01	56	11	56
30345	44441	172	Total Export AH OF	01	58	11	58
30347	44443	173	Old AH Import Ch1 OF	01	5A	11	5A
30349	44445	174	Old AH Import Ch2 OF	01	5C	11	5C
30351	44447	175	Old AH Import Ch3 OF	01	5E	11	5E
30353	44449	176	Old AH Import Ch4 OF	01	60	11	60
30355	44451	177	Old AH Export Ch1 OF	01	62	11	62
30357	44453	178	Old AH Export Ch2 OF	01	64	11	64
30359	44455	179	Old AH Export Ch3 OF	01	66	11	66
30361	44457	180	Old AH Export Ch4 OF	01	68	11	68
30363	44459	181	Relay 1 Status	01	6A	11	6A
30365	44461	182	Relay 2 Status	01	6C	11	6C
30367	44463	183	Relay 3 Status	01	6E	11	6E
30369	44465	184	Relay 4 Status	01	70	11	70
30371	44467	185	Timer 1 On Delay	01	72	11	72
30373	44469	186	Timer 2 On Delay	01	74	11	74

TABLE 1 : Continued...

Address (3X)	Address (4X)	Parameter Number	Parameter	Start Address Hex 3X		Start Address Hex 4X	
				High Byte	Low Byte	High Byte	Low Byte
30375	44471	187	Timer 3 On Delay	01	76	11	76
30377	44473	188	Timer 4 On Delay	01	78	11	78
30379	44475	189	Timer 1 Off Delay	01	7A	11	7A
30381	44477	190	Timer 2 Off Delay	01	7C	11	7C
30383	44479	191	Timer 3 Off Delay	01	7E	11	7E
30385	44481	192	Timer 4 Off Delay	01	80	11	80
30387	44483	193	Timer 1 No of Cycles	01	82	11	82
30389	44485	194	Timer 2 No of Cycles	01	84	11	84
30391	44487	195	Timer 3 No of Cycles	01	86	11	86
30393	44489	196	Timer 4 No of Cycles	01	88	11	88
30395	44491	197	RTC Min	01	8A	11	8A
30397	44493	198	RTC Hour	01	8C	11	8C
30399	44495	199	RTC Day of Week	01	8E	11	8E
30401	44497	200	RTC Date	01	90	11	90
30403	44499	201	RTC Month	01	92	11	92
30405	44501	202	RTC Year	01	94	11	94
30407	44503	203	RTC Complete Date*	01	96	11	96
30409	44505	204	RTC Complete Time*	01	98	11	98

* RTC complete date is shown in "ddmmyy" format & RTC complete time is shown in "hh.mm" format.

TABLE 2 : 3X and 4X register addresses for 32-bit Integer Energy

Address (3X)	Address (4X)	Parameter	Start Address Hex 3X		Start Address Hex 4X	
			High Byte	Low Byte	High Byte	Low Byte
30769	44865	Energy Imp Ch1	03	00	13	00
30771	44867	Energy Imp Ch2	03	02	13	02
30773	44869	Energy Imp Ch3	03	04	13	04
30775	44871	Energy Imp Ch4	03	06	13	06
30777	44873	Energy Import Ch1 OF	03	08	13	08
30779	44875	Energy Import Ch2 OF	03	0A	13	0A
30781	44877	Energy Import Ch3 OF	03	0C	13	0C
30783	44879	Energy Import Ch4 OF	03	0E	13	0E
30785	44881	Energy Exp Ch1	03	10	13	10
30787	44883	Energy Exp Ch2	03	12	13	12
30789	44885	Energy Exp Ch3	03	14	13	14
30791	44887	Energy Exp Ch4	03	16	13	16
30793	44889	Energy Export Ch1 OF	03	18	13	18
30795	44891	Energy Export Ch2 OF	03	1A	13	1A
30797	44893	Energy Export Ch3 OF	03	1C	13	1C
30799	44895	Energy Export Ch4 OF	03	1E	13	1E
30801	44897	Total Import Energy	03	20	13	20
30803	44899	Total Import Energy OF	03	22	13	22
30805	44901	Total Export Energy	03	24	13	24
30807	44903	Total Export Energy OF	03	26	13	26
30809	44905	Energy Imp Ch1 on update rate*	03	28	13	28
30811	44907	Energy Imp Ch2 on update rate*	03	2A	13	2A

TABLE 2 : Continued...

Address (3X)	Address (4X)	Parameter	Start Address Hex 3X		Start Address Hex 4X	
			High Byte	Low Byte	High Byte	Low Byte
30813	44909	Energy Imp Ch3 on update rate*	03	2C	13	2C
30815	44911	Energy Imp Ch4 on update rate*	03	2E	13	2E
30817	44913	Energy Import Ch1 on update rate OF*	03	30	13	30
30819	44915	Energy Import Ch2 on update rate OF*	03	32	13	32
30821	44917	Energy Import Ch3 on update rate OF*	03	34	13	34
30823	44919	Energy Import Ch4 on update rate OF*	03	36	13	36
30825	44921	Energy Exp Ch1 on update rate*	03	38	13	38
30827	44923	Energy Exp Ch2 on update rate*	03	3A	13	3A
30829	44925	Energy Exp Ch3 on update rate*	03	3C	13	3C
30831	44927	Energy Exp Ch4 on update rate*	03	3E	13	3E
30833	44929	Energy Export Ch1 on update rate OF*	03	40	13	40
30835	44931	Energy Export Ch2 on update rate OF*	03	42	13	42
30837	44933	Energy Export Ch3 on update rate OF*	03	44	13	44
30839	44935	Energy Export Ch4 on update rate OF*	03	46	13	46
30841	44937	Amp Hour Imp Ch1	03	48	13	48
30843	44939	Amp Hour Imp Ch2	03	4A	13	4A
30845	44941	Amp Hour Imp Ch3	03	4C	13	4C
30847	44943	Amp Hour Imp Ch4	03	4E	13	4E
30849	44945	AH Import Ch1 OF	03	50	13	50
30851	44947	AH Import Ch2 OF	03	52	13	52
30853	44949	AH Import Ch3 OF	03	54	13	54
30855	44951	AH Import Ch4 OF	03	56	13	56

TABLE 2 : Continued...

Address (3X)	Address (4X)	Parameter	Start Address Hex 3X		Start Address Hex 4X	
			High Byte	Low Byte	High Byte	Low Byte
30857	44953	Amp Hour Exp Ch1	03	58	13	58
30859	44955	Amp Hour Exp Ch2	03	5A	13	5A
30861	44957	Amp Hour Exp Ch3	03	5C	13	5C
30863	44959	Amp Hour Exp Ch4	03	5E	13	5E
30865	44961	AH Export Ch1 OF	03	60	13	60
30867	44963	AH Export Ch2 OF	03	62	13	62
30869	44965	AH Export Ch3 OF	03	64	13	64
30871	44967	AH Export Ch4 OF	03	66	13	66
30873	44969	Total Import AH	03	68	13	68
30875	44971	Total Import AH OF	03	6A	13	6A
30877	44973	Total Export AH	03	6C	13	6C
30879	44975	Total Export AH OF	03	6E	13	6E
30881	44977	On Hour	03	70	13	70
30883	44979	Run Hour Ch1	03	72	13	72
30885	44981	Run Hour Ch2	03	74	13	74
30887	44983	Run Hour Ch3	03	76	13	76
30889	44985	Run Hour Ch4	03	78	13	78
30891	44987	Old Energy Imp Ch 1	03	7A	13	7A
30893	44989	Old Energy Imp Ch 2	03	7C	13	7C
30895	44991	Old Energy Imp Ch 3	03	7E	13	7E
30897	44993	Old Energy Imp Ch 4	03	80	13	80
30899	44995	Old Energy Import Ch1 OF	03	82	13	82

TABLE 2 : Continued...

Address (3X)	Address (4X)	Parameter	Start Address Hex 3X		Start Address Hex 4X	
			High Byte	Low Byte	High Byte	Low Byte
30901	44997	Old Energy Import Ch2 OF	03	84	13	84
30903	44999	Old Energy Import Ch3 OF	03	86	13	86
30905	45001	Old Energy Import Ch4 OF	03	88	13	88
30907	45003	Old Energy Exp Ch 1	03	8A	13	8A
30909	45005	Old Energy Exp Ch 2	03	8C	13	8C
30911	45007	Old Energy Exp Ch 3	03	8E	13	8E
30913	45009	Old Energy Exp Ch 4	03	90	13	90
30915	45011	Old Energy Export Ch1 OF	03	92	13	92
30917	45013	Old Energy Export Ch2 OF	03	94	13	94
30919	45015	Old Energy Export Ch3 OF	03	96	13	96
30921	45017	Old Energy Export Ch4 OF	03	98	13	98
30923	45019	Old Amp Hour Imp Ch1	03	9A	13	9A
30925	45021	Old Amp Hour Imp Ch2	03	9C	13	9C
30927	45023	Old Amp Hour Imp Ch3	03	9E	13	9E
30929	45025	Old Amp Hour Imp Ch4	03	A0	13	A0
30931	45027	Old AH Import Ch1 OF	03	A2	13	A2
30933	45029	Old AH Import Ch2 OF	03	A4	13	A4
30935	45031	Old AH Import Ch3 OF	03	A6	13	A6
30937	45033	Old AH Import Ch4 OF	03	A8	13	A8
30939	45035	Old Amp Hour Exp Ch1	03	AA	13	AA
30941	45037	Old Amp Hour Exp Ch2	03	AC	13	AC
30943	45039	Old Amp Hour Exp Ch3	03	AE	13	AE

TABLE 2 : Continued...

Address (3X)	Address (4X)	Parameter	Start Address Hex 3X		Start Address Hex 4X	
			High Byte	Low Byte	High Byte	Low Byte
30945	45041	Old Amp Hour Exp Ch4	03	B0	13	B0
30947	45043	Old AH Export Ch1 OF	03	B2	13	B2
30949	45045	Old AH Export Ch2 OF	03	B4	13	B4
30951	45047	Old AH Export Ch3 OF	03	B6	13	B6
30953	45049	Old AH Export Ch4 OF	03	B8	13	B8
30955	45051	Old On Hour	03	BA	13	BA
30957	45053	Old Run Hour Ch1	03	BC	13	BC
30959	45055	Old Run Hour Ch2	03	BE	13	BE
30961	45057	Old Run Hour Ch3	03	C0	13	C0
30963	45059	Old Run Hour Ch4	03	C2	13	C2

*These values are updated depending on update rate which can be changed by user. For example, if user has set update rate 10 minute, then the values on these registers will be updated every 10 min.

3.2 Accessing 4X register for Reading & Writing Settings:

Each setting is held in the 4X registers. ModBus code 03 is used to read the current setting & code 16 is used to write/change the setting. Refer **TABLE 3** for 4X Register addresses.

Example: Reading Nominal Voltage

Nominal Voltage: Start address = 1A (Hex) Number of registers = 02

(Note: Number of registers = Number of Parameters x 2)

Query :

Device Address	01 (Hex)
Function Code	03 (Hex)
Start Address High	00 (Hex)
Start Address Low	1A (Hex)
Number of Registers High	00 (Hex)
Number of Registers Low	02 (Hex)
CRC Low	E5 (Hex)
CRC High	CC (Hex)

Response (Nominal voltage 24V):

Device Address	01 (Hex)
Function Code	03 (Hex)
Byte Count	04 (Hex)
Data Register1 High Byte	41 (Hex)
Data Register1Low Byte	C0 (Hex)
Data Register2 High Byte	00 (Hex)
Data Register2 Low Byte	00(Hex)
CRC Low	44 (Hex)
CRC High	C6 (Hex)

Start Address High: Most significant 8 bits of starting address of the parameter requested.

Start Address low: Least significant 8 bits of starting address of the parameter requested.

Number of register High: Most significant 8 bits of Number of registers requested.

Number of register Low: Least significant 8 bits of Number of registers requested.

Byte Count: Total number of data bytes received.

Data register 1 High Byte : Most significant 8 bits of Data register 1 of the parameter requested.

Data register 1 Low Byte : Least significant 8 bits of Data register 1 of the parameter requested.

Data register 2 High Byte : Most significant 8 bits of Data register 2 of the parameter requested.

Data register 2 Low Byte : Least significant 8 bits of Data register 2 of the parameter requested.

(Note : Two consecutive 16 bit register represent one parameter.)

Example : Writing Nominal Voltage

Nominal Voltage: Start address = 1A (Hex) Number of registers = 02

Query:(Change Nominal Voltage to 48 V)

Device Address	01 (Hex)
Function Code	10 (Hex)
Starting Address Hi	00 (Hex)
Starting Address Lo	1A(Hex)
Number of Registers Hi	00 (Hex)
Number of Registers Lo	02(Hex)
Byte Count	04 (Hex)
Data Register-1High Byte	42 (Hex)
Data Register-1 Low Byte	40(Hex)
Data Register-2 High Byte	00(Hex)
Data Register-2 Low Byte	00(Hex)
CRC Low	67 (Hex)
CRC High	70 (Hex)

Response:

Device Address	01 (Hex)
Function Code	10 (Hex)
Start Address High	00 (Hex)
Start Address Low	1A(Hex)
Number of Registers Hi	00 (Hex)
Number of Registers Lo	02(Hex)
CRC Low	60 (Hex)
CRC High	0F (Hex)

Byte Count : Total number of data bytes received.

Data register 1 High Byte : Most significant 8 bits of Data register 1 of the parameter requested.

Data register 1 Low Byte : Least significant 8 bits of Data register 1 of the parameter requested.

Data register 2 High Byte : Most significant 8 bits of Data register 2 of the parameter requested.

Data register 2 Low Byte : Least significant 8 bits of Data register 2 of the parameter requested.

StartAddress High : Most significant 8 bits of starting address of the parameter requested.

StartAddress low : Least significant 8 bits of starting address of the parameter requested.

Number of register Hi : Most significant 8 bits of Number of registers requested.

Number of register Lo : Least significant 8 bits of Number of registers requested.

(Note : Two consecutive 16 bit register represent one parameter.)

TABLE 3 : 4X register addresses

Address	Parameters	Read / write	Start Address Hex		Default Values
			High byte	Low byte	
40003	Demand Integration Time	R/Wp	00	2	1
40005	Reset parameters	R/Wp	00	4	0
40007	RS485 Setup Code	R/Wp	00	6	4
40009	Mod address	R/Wp	00	8	1
40027	Nominal Voltage	R/Wp	00	1A	48,110,1000*
40029	Auto Detect Nominal Voltage	R/Wp	00	1C	0
40031	Channel Select	R/Wp	00	1E	11111
40033	Current - Full Scale Ch1	R/Wp	00	20	5
40035	Current - Full Scale Ch2	R/Wp	00	22	5
40037	Current - Full Scale Ch3	R/Wp	00	24	5
40039	Current - Full Scale Ch4	R/Wp	00	26	5
40041	Current - Shunt Ch1	R/Wp	00	28	75
40043	Current - Shunt Ch2	R/Wp	00	2A	75
40045	Current - Shunt Ch3	R/Wp	00	2C	75
40047	Current - Shunt Ch4	R/Wp	00	2E	75
40053	Energy Ch1 update rate	R/Wp	00	34	15
40055	Energy Ch2 update rate	R/Wp	00	36	15
40057	Energy Ch3 update rate	R/Wp	00	38	15
40059	Energy Ch4 update rate	R/Wp	00	3A	15
40061	Energy Output Ch1	R/Wp	00	3C	2
40063	Energy Output Ch2	R/Wp	00	3E	2
40065	Energy Output Ch3	R/Wp	00	40	2
40067	Energy Output Ch4	R/Wp	00	42	2
40069	Noise Current Cutoff	R/Wp	00	44	0
40073	Register order	R/Wp	00	48	0

* This value differs according to meter range. It is 48, 110 & 1000 for 10-60 V, 61-200 V & 201-1000 V meters respectively.

TABLE 3 : Continued...

Address	Parameters	Read / write	Start Address Hex		Default Values
			High byte	Low byte	
40075	Auto Scroll	R/Wp	00	4A	-
40077	Reverse Lock Ch1	R/Wp	00	4C	0
40079	Reverse Lock Ch2	R/Wp	00	4E	0
40081	Reverse Lock Ch3	R/Wp	00	50	0
40083	Reverse Lock Ch4	R/Wp	00	52	0
40085	Energy Digit Reset Count Ch1	R/Wp	00	54	8
40087	Energy Digit Reset Count Ch2	R/Wp	00	56	8
40089	Energy Digit Reset Count Ch3	R/Wp	00	58	8
40091	Energy Digit Reset Count Ch4	R/Wp	00	5A	8
40093	Factory Reset	R/Wp	00	5C	0
40095	Password	R/W	00	5E	0
40097	Serial Number	R/Wp	00	60	-
40099	Model Number	R/Wp	00	62	6001/6002
40101	Firmware Version Number	R/Wp	00	64	-
40103	User Assignable Screen On/OFF	R/Wp	00	66	0
40105	User Screen 1	R/Wp	00	68	1
40107	User Screen 2	R/Wp	00	6A	2
40109	User Screen 3	R/Wp	00	6C	3
40111	User Screen 4	R/Wp	00	6E	6
40113	User Screen 5	R/Wp	00	70	7
40115	User Screen 6	R/Wp	00	72	10
40117	User Screen 7	R/Wp	00	74	11
40119	User Screen 8	R/Wp	00	76	14
40121	User Screen 9	R/Wp	00	78	15
40123	User Screen 10	R/Wp	00	7A	18

TABLE 3 : Continued...

Address	Parameters	Read / write	Start Address Hex		Default Values
			High byte	Low byte	
40125	Pulse Divisor for pulse output 1	R/Wp	00	7C	1
40127	Pulse Divisor for pulse output 2	R/Wp	00	7E	1
40133	Pulse Width for pulse output	R/Wp	00	84	100
40219	Relay 1 Output Select	R/Wp	00	DA	0
40221	Para Select / No of cycles / Weekly Repeat	R/Wp	00	DC	0
40223	Relay 1 Configuration Select	R/Wp	00	DE	0
40225	Limit 1 trip point	R/Wp	00	E0	0
40227	Hysteresis (Limit 1)	R/Wp	00	E2	0
40229	Relay 1 / On Delay (Energize) / On time	R/Wp	00	E4	0
40231	Relay 1 / Off Delay (De-energize) / Off time	R/Wp	00	E6	0
40233	Relay 2 Output Select	R/Wp	00	E8	0
40235	Para Select / No of cycles / Weekly Repeat	R/Wp	00	EA	0
40237	Relay 2 Configuration Select	R/Wp	00	EC	0
40239	Limit 2 trip point	R/Wp	00	EE	0
40241	Hysteresis (Limit 2)	R/Wp	00	F0	0
40243	Relay 2 / On Delay (Energize) / On time	R/Wp	00	F2	0
40245	Relay 2 / Off Delay (De-energize) / Off time	R/Wp	00	F4	0
40247	Relay 3 Output Select	R/Wp	00	F6	0
40249	Para Select / No of cycles / Weekly Repeat	R/Wp	00	F8	0
40251	Relay 3 Configuration Select	R/Wp	00	FA	0
40253	Limit 3 trip point	R/Wp	00	FC	0
40255	Hysteresis (Limit 3)	R/Wp	00	FE	0
40257	Limit 3 / On Delay (Energize) / On time	R/Wp	01	0	0

TABLE 3 : Continued...

Address	Parameters	Read / write	Start Address Hex		Default Values
			High byte	Low byte	
40259	Limit 3 / Off Delay (De-energize) / Off time	R/Wp	01	2	0
40261	Relay 4 Output Select	R/Wp	01	4	0
40263	Para Select / No of cycles / Weekly Repeat	R/Wp	01	6	0
40265	Relay 4 Configuration Select	R/Wp	01	8	0
40267	Limit 4 trip point	R/Wp	01	0A	0
40269	Hysteresis (Limit 4)	R/Wp	01	0C	0
40271	Relay 4 / On Delay (Energize) / On time	R/Wp	01	0E	0
40273	Relay 4 / Off Delay (De-energize) / Off time	R/Wp	01	10	0
40303	Relay 1 Status & Remote Operation	R/Wp	01	2E	0
40305	Relay 2 Status & Remote Operation	R/Wp	01	30	0
40307	Relay 3 Status & Remote Operation	R/Wp	01	32	0
40309	Relay 4 Status & Remote Operation	R/Wp	01	34	0
40311	Timer 1 Start / Stop	R/Wp	01	36	0
40313	Timer 2 Start / Stop	R/Wp	01	38	0
40315	Timer 3 Start / Stop	R/Wp	01	3A	0
40317	Timer 4 Start / Stop	R/Wp	01	3C	0
40319	Energy Imp Ch1 Starting Count	R/Wp	01	3E	0
40321	Energy Imp Ch2 Starting Count	R/Wp	01	40	0
40323	Energy Imp Ch3 Starting Count	R/Wp	01	42	0
40325	Energy Imp Ch4 Starting Count	R/Wp	01	44	0
40327	Energy Exp Ch1 Starting Count	R/Wp	01	46	0
40329	Energy Exp Ch2 Starting Count	R/Wp	01	48	0
40331	Energy Exp Ch3 Starting Count	R/Wp	01	4A	0
40333	Energy Exp Ch4 Starting Count	R/Wp	01	4C	0

TABLE 3 : Continued...

Address	Parameters	Read / write	Start Address Hex		Default Values
			High byte	Low byte	
40337	RTC Min	R/Wp	01	50	-
40339	RTC Hour	R/Wp	01	52	-
40341	RTC Day of Week	R	01	54	-
40343	RTC Date	R/Wp	01	56	-
40345	RTC Month	R/Wp	01	58	-
40347	RTC Year	R/Wp	01	5A	-
40349	RTC Complete Date	R/Wp	01	5C	-
40351	RTC Complete Time	R/Wp	01	5E	-
40353	Current Screen No	R	01	60	1
40361	Password for Energy Starting Count	R/Wp	01	68	0
40365	Event-based Datalog Select	R/Wp	01	6C	0
40367	Time-based Datalog Select	R/Wp	01	6E	0
40369	Time-based Datalog Interval Selection	R/Wp	01	70	0
40371	Logging Parameter Count	R/Wp	01	72	0
40373	Datalog Parameter 1	R/Wp	01	74	0
40375	Datalog Parameter 2	R/Wp	01	76	0
40377	Datalog Parameter 3	R/Wp	01	78	0
40379	Datalog Parameter 4	R/Wp	01	7A	0
40381	Datalog Parameter 5	R/Wp	01	7C	0
40383	Datalog Parameter 6	R/Wp	01	7E	0
40385	Datalog Parameter 7	R/Wp	01	80	0
40387	Datalog Parameter 8	R/Wp	01	82	0
40389	Datalog Parameter 9	R/Wp	01	84	0
40391	Datalog Parameter 10	R/Wp	01	86	0
40393	Datalog Parameter 11	R/Wp	01	88	0

TABLE 3 : Continued...

Address	Parameters	Read / write	Start Address Hex		Default Values
			High byte	Low byte	
40395	Datalog Parameter 12	R/Wp	01	8A	0
40397	Datalog Parameter 13	R/Wp	01	8C	0
40399	Datalog Parameter 14	R/Wp	01	8E	0
40401	Datalog Parameter 15	R/Wp	01	90	0
40403	Datalog Parameter 16	R/Wp	01	92	0
40405	Datalog Parameter 17	R/Wp	01	94	0
40407	Datalog Parameter 18	R/Wp	01	96	0
40409	Datalog Parameter 19	R/Wp	01	98	0
40411	Datalog Parameter 20	R/Wp	01	9A	0
40413	Datalog Parameter 21	R/Wp	01	9C	0
40415	Datalog Parameter 22	R/Wp	01	9E	0
40417	Datalog Parameter 23	R/Wp	01	A0	0
40419	Datalog Parameter 24	R/Wp	01	A2	0
40421	Datalog Parameter 25	R/Wp	01	A4	0
40423	Datalog Parameter 26	R/Wp	01	A6	0
40425	Datalog Parameter 27	R/Wp	01	A8	0
40427	Datalog Parameter 28	R/Wp	01	AA	0
40429	Datalog Parameter 29	R/Wp	01	AC	0
40431	Datalog Parameter 30	R/Wp	01	AE	0
40433	Load Profile Datalog Select	R/Wp	01	B0	0
40435	Start Date of Load Profile Datalog Ch 1	R	01	B2	0
40437	Start Date of Load Profile Datalog Ch 2	R	01	B4	0
40439	Start Date of Load Profile Datalog Ch 3	R	01	B6	0
40441	Start Date of Load Profile Datalog Ch 4	R	01	B8	0

TABLE 3 : Continued...

Address	Parameters	Read / write	Start Address Hex		Default Values
			High byte	Low byte	
40477	Restart Meter	R/Wp	01	DC	0
40479	EEPROM Error	R	01	DE	0
40481	RTC Error	R	01	E0	0
40483	Flash Error	R	01	E2	0
40485	Write in Process	R	01	E4	0
40487	RTC Battery Low	R	01	E6	0

NOTE:

Wp - Write protected

R - Read only

R/W - Read & Write

R/Wp - Read & Write protected

TABLE 4: Explanation for 4X register:

Note: Writing any invalid values(non-applicable values) to any of the following locations will result in modbus error.

Address	Parameter	Description
40003	Demand Integration Time	Demand integration time represents demand time in minutes. The applicable values are 1-30.
40005	Reset parameters	This address is used to reset different parameters. Write specific value to this register to reset the corresponding parameter. Refer Table 5.
40007	RS485 Setup Code	This address is used to set the baud rate, Parity, Number of stop bits. Refer Table 6.
40009	Modbus address	This value is used to read and write device address of the device. Valid values are 1-247.
40027	Nominal Voltage	This address is used to read and write nominal voltage of the system. Valid values ranges are as following and change with order code. 10 - 60V 61 - 200V 201 - 1000V
40029	Auto Detect Nominal Voltage	Writing 1 here will change the value of nominal voltage of the meter to a preset value according to the input voltage at that time irrespective of voltage polarity. Refer Table 7.
40031	Channel Select	User can view and change active channels here. Valid values 1xxxx (where x is 0 or 1 and each x corresponds to channels 1,2,3 & 4 respectively). Eg 11010 means only Ch1 & Ch3 is selected.
40033	Current - Full Scale Ch1	These addresses are used to read and write full scale current values in ampere for each channel. Valid value range is 1-20000 A.
40035	Current - Full Scale Ch2	
40037	Current - Full Scale Ch3	
40039	Current - Full Scale Ch4	
40041	Current - Shunt Ch1	These addresses are used to read and write the shunt voltage drop for full scale current in millivolts for each channel. Valid value range is 50-150 mV.
40043	Current - Shunt Ch2	
40045	Current - Shunt Ch3	
40047	Current - Shunt Ch4	

Address	Parameter	Description
40053	Energy Ch1 update rate	This address is used to specify update rate of energy in corresponding 3X registers. The valid values for update rate are from 1 to 60 min.
40055	Energy Ch2 update rate	
40057	Energy Ch3 update rate	
40059	Energy Ch4 update rate	
40061	Energy Output Ch1	This address is used to set energy output in Wh,kWh & MWh. Write one of the following value to this address. 1: Energy in Wh (only valid when channel nominal power is less than 60kW) 2: Energy in KWh 3: Energy in MWh
40063	Energy Output Ch2	
40065	Energy Output Ch3	
40067	Energy Output Ch4	
40069	Noise Current Cutoff	This address is used to activate or de-activate the noise current elimination.Noise current is in percentage of nominal current. Valid values 0-30. 0: deactivate 1-30: noise current is cut off below this percent of nominal current.
40073	Register order	Word Order controls the order in which meter receives or sends floating - point numbers:- normal or reversed register order . In normal mode, the two registers that make up a floating point numbers are sent most significant bytes first. In reversed register mode , the two registers that make up a floating point numbers are sent least significant bytes first. To set the mode, write the value '2141.0' into this register-the instrument will detect the order used to send this value and set that order for all ModBus transaction involving floating point numbers.
40075	Auto Scroll	This address is used to activate or de-activate the auto scrolling. 0: Deactivate 1: Activate
40077	Reverse Lock Ch1	These addresses are used to read and write the reverse locking parameter for each channel. Reverse locking is when the current or power is in the opposite direction of the desired direction, the energy and/or ampere-hour accumulation is stopped for the related channel. Valid values are: 0: No reverse locking 1: Positive/ Import locking 2: Negative/ Export locking
40079	Reverse Lock Ch2	
40081	Reverse Lock Ch3	
40083	Reverse Lock Ch4	

Address	Parameter	Description
40085	Energy Digit Reset Count Ch1	This address is used to set Energy Digit Reset Count value. Energy count can be configured to reset on 6,7 or 8.
40087	Energy Digit Reset Count Ch2	
40089	Energy Digit Reset Count Ch3	
40091	Energy Digit Reset Count Ch4	
40093	Factory Reset	This address allows the user to reset the instrument to factory settings. Refer the Default Values in Table 3 for factory settings. Write 100 at this address to reset the instrument.
40095	Password	This address is used to set & reset the password. Valid Range of Password can be set is 0000 - 9999. 1) If password lock is present & if this location is read it will return zero. 2) If Password lock is absent & if this location is read it will return one. 3) If password lock is present & to disable this lock first send valid password to this location then write "0000" to this location. 4) If password lock is present & to modify 4X parameter first send valid password to this location so that 4X parameter will be accessible for modification. 5) If in any of the above case invalid password is sent then meter will return exceptional error 2.
40097	Serial Number	This address is read only and displays the serial number of the meter.
40099	Model Number	Model number of the meter. 6001: Without USB, RTC & Datalogging 6002: With USB, RTC & Datalogging
40101	Firmware Version Number	This address is read only and displays the firmware version of the meter.
40103	User Assignable Screen On/OFF	This address is used to read and write if the user assignable screens are on or off and how many user screens are shown. Valid values are: 0: Deactivate 1-10: This many user screens are shown
40105	User Screen 1	These addresses are used to assign the screen numbers to user screens 1 to 10 respectively. Refer to Table 15 for screen numbers.
40107	User Screen 2	
...	...	
40123	User Screen 10	

Address	Parameter	Description
40125	Pulse Divisor for pulse output 1	This address is used to set pulse divisor of the Pulse output. Refer Table 8.
40127	Pulse Divisor for pulse output 2	
40133	Pulse Width for pulse output	This address is used to set pulse width of the Pulse output. Write one of the following values to this address: 60 : 60 ms 100 : 100 ms 200 : 200 ms
40219	Relay 1 Output Select	This address is used to select the Relay operation. Write one of the following values to this address. 0: None 1: Limit 2: Pulse 3: Timer 4: Remote Op 5: Reverse Lock 6: RTC relay
40221	Para Select / No of cycles / Weekly Repeat	This address is used to assign the Parameter to Relay. Limit relay: Refer Table 9 Pulse relay: Refer Table 10 Timer relay: Refer Table 11 Reverse lock relay: Refer Table 12 RTC relay: Refer Table 13
40223	Relay 1 Configuration Select	This address is used to read and write the relay configuration. Refer Table 14.
40225	Limit 1 trip point	This address is used to set the trip point in %. Any value between 10 to 100 for Lo-alarm & 10 to 120 for Hi-alarm can be written to this address. For energy and ampere hour parameters the valid range range is 10-9999999. (refer Table 9)
40227	Hysteresis (Limit 1)	This address is used to set the hysteresis percentage. Valid values are between 0.5 to 50.0
40229	Relay 1 / On Delay (Energize) / On time	This address is used to set the Energizing delay in seconds in range of 1-9999. For RTC relay this range is 00.00 to 23.59.
40231	Relay 1 / Off Delay (De-energize) / Off time	This address is used to set the Energizing delay in seconds in range of 1-9999. For RTC relay this range is 00.00 to 23.59.

Address	Parameter	Description
40233	Relay 2 Output Select	Same as relay 1.
40235	Para Select / No of cycles / Weekly Repeat	
40237	Relay 2 Configuration Select	
40239	Limit 2 trip point	
40241	Hysteresis (Limit 2)	
40243	Relay 2 / On Delay (Energize) / On time	
40245	Relay 2 / Off Delay (De-energize) / Off time	
40247	Relay 3 Output Select	
40249	Para Select / No of cycles / Weekly Repeat	
40251	Relay 3 Configuration Select	
40253	Limit 3 trip point	
40255	Hysteresis (Limit 3)	
40257	Relay 3 / On Delay (Energize) / On time	
40259	Relay 3 / Off Delay (De-energize) / Off time	
40261	Relay 4 Output Select	Same as relay 1. (Pulse output is not available)
40263	Para Select / No of cycles / Weekly Repeat	
40265	Relay 4 Configuration Select	
40267	Limit 4 trip point	
40269	Hysteresis (Limit 4)	
40271	Relay 4 / On Delay (Energize) / On time	
40273	Relay 4 / Off Delay (De-energize) / Off time	
40303	Relay 1 Status & Remote Operation	
40305	Relay 2 Status & Remote Operation	
40307	Relay 3 Status & Remote Operation	
40309	Relay 4 Status & Remote Operation	

Address	Parameter	Description
40311	Timer 1 Start / Stop	These addresses can be used to start or stop the timers. 0: Stop 1: Start
40313	Timer 2 Start / Stop	
40315	Timer 3 Start / Stop	
40317	Timer 4 Start / Stop	
40319	Energy Imp Ch1 Starting Count	The user can set energy starting count for each channel in these registers (before the user can write values to these locations he/she needs to check register 40361 for password lock). Valid range is 0-99999999.
40321	Energy Imp Ch2 Starting Count	
40323	Energy Imp Ch3 Starting Count	
40325	Energy Imp Ch4 Starting Count	
40327	Energy Exp Ch1 Starting Count	
40329	Energy Exp Ch2 Starting Count	
40331	Energy Exp Ch3 Starting Count	
40333	Energy Exp Ch4 Starting Count	
40337	RTC Min	This address is used to read and write the minute part from RTC. Valid range 0-59.
40339	RTC Hour	This register decides the hour part from RTC. Valid range 0-23.
40341	RTC Day of Week	This register shows the day of week part from RTC. This address is read only. 1: Sunday 2: Monday 3: Tuesday 4: Wednesday 5: Thursday 6: Friday 7: Saturday
40343	RTC Date	This address is used to read and write the date part from RTC.
40345	RTC Month	This address is used to read and write the month part from RTC.
40347	RTC Year	This address is used to read and write the year part from RTC. Valid range 2000-2099.
40349	RTC Complete Date	This address is used to read and write full date in "ddmmyy" format from RTC.
40351	RTC Complete Time	This address is used to read and write complete time in "hh.mm" format from RTC.
40353	Current Screen No	This read only register shows the screen number of the screen currently being displayed.

Address	Parameter	Description
40361	Password for Energy Starting Count	This address is used to set & reset the password for energy starting count. This is additional protection for Energy Starting Count. This address can only be modified after entering a valid password at address 40095. Valid Range of Password can be set is 0000 - 9999. 1) If password lock is present & if this location is read it will return zero. 2) If Password lock is absent & if this location is read it will return one. 3) If password lock is present & to disable this lock first send valid password to this location then write "0000" to this location. 4) If password lock is present; to modify "Energy Starting Count", first send valid password to this location so that "Energy Starting Count" will be accessible for modification. 5) In any of the above case if invalid password is sent, the meter will return exceptional error 2.
40365	Event-based Datalog Select	This register is used to enable or disable event based datalogging. 0: Disabled 1: Enabled
40367	Time-based Datalog Select	This register is used to enable or disable time based datalogging. 0: Disabled 1: Enabled
40369	Time-based Datalog Interval Selection	This address is used to read and write the interval between consecutive time log entries in minutes. Valid value range 1-60
40371	Logging Parameter Count	This value decides the number of parameters to be logged in time based datalogging.
40373 to 40431	Datalog Parameter 1 to 30	These addresses are used to read and write the parameters to be logged in time based logging. Valid value range 0-180. Refer Table 1.
40433	Load Profile Datalog Select	User can select channels for load profile logging here. Valid values 1xxxx (where x is 0 or 1 and each x corresponds to channels 1,2,3 & 4 respectively). Eg 11010 means only Ch1 & Ch3 is selected.
40435	Start Date of Load Profile Datalog Ch 1	These values show the starting date for each channel datalog. These addresses are read only.
40437	Start Date of Load Profile Datalog Ch 2	
40439	Start Date of Load Profile Datalog Ch 3	
40441	Start Date of Load Profile Datalog Ch 4	
40477	Restart Meter	

Address	Parameter	Description
40479	EEPROM Error	These values show the errors present if there are any (these registers are read only), 0: No Error 1: Error Present
40481	RTC Error	
40483	Flash Error	
40485	Write in Process	This value shows if the meter is busy in writing process (this register is read only). 0: Idle 1: Busy Writing
40487	RTC Battery Low	This value shows if the RTC battery is low (this register is read only). 0: Battery normal 1: Battery low

TABLE 5: Reset Parameters

Para No / Code	Parameter
0	None
1	All
2	On Hour
3	No of Interrupts
4	High V
5	Low V
6XXXX	High A
7XXXX	Low A
8XXXX	Energy
9XXXX	Demand
12XXXX	AH
13XXXX	Run Hour
14XXXX	Channel Data
15	Time-based Log
16XXXX	Load Profile Log

In reset parameters, the XXXX represent channels 1,2,3 & 4 respectively. To reset a parameter on a particular channel, write 1 in place of corresponding X in the reset code and write 0 otherwise.

Ex. If a user wants to reset energy on channel 1 and 2, the reset code will be 81100.

TABLE 6: Communication Parameters

Baud Rate	Parity	Stop bit	Decimal Value
4800	NONE	1	0
4800	NONE	2	1
4800	EVEN	1	2
4800	ODD	1	3
9600	NONE	1	4
9600	NONE	2	5
9600	EVEN	1	6
9600	ODD	1	7
19200	NONE	1	8
19200	NONE	2	9
19200	EVEN	1	10
19200	ODD	1	11
38400	NONE	1	12
38400	NONE	2	13
38400	EVEN	1	14
38400	ODD	1	15
57600	NONE	1	16
57600	NONE	2	17
57600	EVEN	1	18
57600	ODD	1	19

TABLE 7: Auto Detection of System Nominal Voltage

Nominal Voltage	Input Voltage
10 - 60V Meter	
12	< 18V
24	>= 18 & <36
48	>= 36 & < 56
60	> 56
61 - 200V Meter	
72	< 90
110	>= 90 & < 135
160	>= 135 & < 180
200	> 180
201 - 1000V Meter	
220	< 235
380	>= 235 & < 450
500	>= 450 & < 600
750	>= 600 & < 800
1000	> 800

TABLE 8: For energy output in Wh

Pulse Rate		
Divisor	Pulse	Channel Power
1	1per Whr	Up to 3600W
	1per kWhr	Up to 60kW
10	1per 10Whr	Up to 3600W
	1per 10kWhr	Up to 60kW
100	1per 100Whr	Up to 3600W
	1per 100kWhr	Up to 60kW
1000	1per 1000Whr	Up to 3600W
	1per 1000kWhr	Up to 60kW

For energy output in kWh

Pulse Rate		
Divisor	Pulse	Channel Power
1	1per kWhr	Up to 3600kW
	1per MWhr	above 3600kW

For energy output in MWh

Pulse Rate	
Divisor	Pulse
1	1per MWhr

TABLE 9: Parameter for Limit Output

Para No.	Parameter	Range
0	None	-----
1	Voltage	$\pm 10 - \pm 120\%$
2	Current Ch 1	$\pm 10 - \pm 120\%$
3	Power Ch1	$\pm 10 - \pm 120\%$
4	Power Imp Demand Ch1	10 - 120%
5	Power Exp Demand Ch1	10 - 120%
6	Import Current Demand Ch1	10 - 120%
7	Export Current Demand Ch1	10 - 120%
8	Power Max Imp Demand Ch1	10 - 120%
9	Power Max Exp Demand Ch1	10 - 120%
10	Max Import Current Demand Ch1	10 - 120%
11	Max Export Current Demand Ch1	10 - 120%
12	Amp Hour Imp Ch1	10 - 9999999
13	Amp Hour Exp Ch1	10 - 9999999
14	Energy Imp Ch1	10 - 9999999
15	Energy Exp Ch1	10 - 9999999
16	Current Ch 2	$\pm 10 - \pm 120\%$
17	Power Ch2	$\pm 10 - \pm 120\%$
18	Power Imp Demand Ch2	10 - 120%
19	Power Exp Demand Ch2	10 - 120%
20	Import Current Demand Ch2	10 - 120%
21	Export Current Demand Ch2	10 - 120%
22	Power Max Imp Demand Ch2	10 - 120%
23	Power Max Exp Demand Ch2	10 - 120%
24	Max Import Current Demand Ch2	10 - 120%
25	Max Export Current Demand Ch2	10 - 120%

TABLE 9: Continued...

Para No.	Parameter	Range
26	Amp Hour Imp Ch2	10 - 9999999
27	Amp Hour Exp Ch2	10 - 9999999
28	Energy Imp Ch2	10 - 9999999
29	Energy Exp Ch2	10 - 9999999
30	Current Ch 3	$\pm 10 - \pm 120\%$
31	Power Ch3	$\pm 10 - \pm 120\%$
32	Power Imp Demand Ch3	10 - 120%
33	Power Exp Demand Ch3	10 - 120%
34	Import Current Demand Ch3	10 - 120%
35	Export Current Demand Ch3	10 - 120%
36	Power Max Imp Demand Ch3	10 - 120%
37	Power Max Exp Demand Ch3	10 - 120%
38	Max Import Current Demand Ch3	10 - 120%
39	Max Export Current Demand Ch3	10 - 120%
40	Amp Hour Imp Ch3	10 - 9999999
41	Amp Hour Exp Ch3	10 - 9999999
42	Energy Imp Ch3	10 - 9999999
43	Energy Exp Ch3	10 - 9999999
44	Current Ch 4	$\pm 10 - \pm 120\%$
45	Power Ch4	$\pm 10 - \pm 120\%$
46	Power Imp Demand Ch4	10 - 120%
47	Power Exp Demand Ch4	10 - 120%
48	Import Current Demand Ch4	10 - 120%
49	Export Current Demand Ch4	10 - 120%
50	Power Max Imp Demand Ch4	10 - 120%

Para No.	Parameter	Range
51	Power Max Exp Demand Ch4	10 - 120%
52	Max Import Current Demand Ch4	10 - 120%
53	Max Export Current Demand Ch4	10 - 120%
54	Amp Hour Imp Ch4	10 - 9999999
55	Amp Hour Exp Ch4	10 - 9999999
56	Energy Imp Ch4	10 - 9999999
57	Energy Exp Ch4	10 - 9999999
58	Total Import Power	10 - 120%
59	Total Export Power	10 - 120%
60	Total Import Power Demand	10 - 120%
61	Total Export Power Demand	10 - 120%
62	Total Import Current Demand	10 - 120%
63	Total Export Current Demand	10 - 120%
64	Total Import AH	10 - 9999999
65	Total Export AH	10 - 9999999
66	Total Import Energy	10 - 9999999
67	Total Export Energy	10 - 9999999

TABLE 10: Parameter for Pulse Output

Code	Configuration
0	Import Energy ch1
1	Import Energy ch2
2	Import Energy ch3
3	Import Energy ch4
4	Export Energy ch1
5	Export Energy ch2
6	Export Energy ch3
7	Export Energy ch4

TABLE 11: Number of Cycles for Timer Relay

Code	Description
0	Unlimited
1 to 9999	Fixed Cycles

TABLE 12: Relay parameter for Reverse Locking

Code	Value
0	None
1	Rev Lock Ch1
2	Rev Lock Ch2
3	Rev Lock Ch3
4	Rev Lock Ch4

TABLE 13: Weekly Repeat for RTC Relay

Code	Description
1XXXXXXX	Eg 11010000 means relay will operate only on Sun & Tue
	1 = Sunday, 7 = Saturday

TABLE 14: Relay Configuration

For Limit Relay

Code	Configuration
0	Hi - alarm & energised Relay
1	Hi - alarm & De-energised Relay
2	Lo - alarm & Energised Relay
3	Lo - alarm & De-energised Relay

For Timer, Reverse lock or RTC relay

Code	Configuration
0	Energize when triggered
1	De-energize when triggered

TABLE 15 : Measurement Screens

Screen No.	Screen Name
1	Voltage
2	Current - Ch1 Ch2 Ch3 Ch4
3	Power - Ch1 Ch2 Ch3 Ch4
4	Total Import Power
5	Total Export Power
6	Import Energy Ch1 - CH4
7	Import Energy Overflow Count
8	Export Energy Ch1 - Ch4
9	Export Energy Overflow Count
10	Total Import Energy
11	Total Export energy
12	Import A-Hr Ch1 - Ch4
13	Import A-Hr Ch1 - Ch4 OF Count
14	Export A-Hr Ch1- Ch4
15	Export A-Hr Ch1- Ch4 OF Count
16	Total Import A-Hr
17	Total Export A-Hr
18	Import POWER Demand Ch1-Ch2-Ch3-CH4
19	Export POWER Demand Ch1-Ch2-Ch3-CH4
20	Total Import Power Demand
21	Total Export Power Demand
22	Import Current Demand Ch1-Ch2-Ch3-CH4
23	Export Current Demand Ch1-Ch2-Ch3-CH4
24	Total Import Current Demand
25	Total Export Current Demand
26	On - hrs
27	Run - hrs Ch1--Ch4
28	Max Voltage

Screen No.	Screen Name
29	Min Voltage
30	MAX Current Ch1-Ch2-Ch3-CH4
31	Min Current Ch1-Ch2-Ch3-CH4
32	Import Max POWER Demand Ch1-Ch2-Ch3-CH4
33	Export Max POWER Demand Ch1-Ch2-Ch3-CH4
34	Import Max Current Demand Ch1-Ch2-Ch3-CH4
35	Export Max Current Demand Ch1-Ch2-Ch3-CH4
36	No of interruptions
37	Old Import Energy Ch1 ---- Ch4
38	Old Import Energy Ch1 ---- Ch4 OF Count
39	Old Export Energy Ch1 --- Ch4
40	Old Export Energy Ch1 ---- Ch4 OF Count
41	Old A-Hr Imp Ch1 --- Ch4
42	Old A-Hr Imp Ch1 --- Ch4 OF Count
43	Old A-Hr Exp Ch1---Ch4
44	Old A-Hr Exp Ch1---Ch4 OF Count
45	Old max Imp Power Demand Ch1 - Ch4
46	Old max Exp Power Demand Ch1 - Ch4
47	Old max Imp Current Demand Ch1 - Ch4
48	Old max Exp Current Demand Ch1 - Ch4
49	Old No of interruptions
50	Old On - hrs
51	Old Run - hrs Ch1--Ch4
52	Timer1 Screen
53	Timer2 Screen
54	Timer3 Screen
55	Timer4 Screen
56	RTC Date (Not present in model 6001)

3.3 User Assignable Modbus Registers:

The Multifunction Energy Meter contains 20 user assignable registers in the address range of 0x200 (30513) to 0x226 (30551) for 3X registers (see TABLE 16) and address range of 0x1E00 (47681) to 0x1E26 (47719) for 4X registers (see TABLE 17).

Any of the parameter addresses (3X register addresses and 4X register addresses TABLE 1) accessible in the instrument can be mapped to these 20 user assignable registers.

Parameters (3X and 4X registers addresses) that reside in different locations may be accessed by the single request by re-mapping them to adjacent address in the user assignable registers area.

The actual address of the parameters (3X and 4X registers addresses) which are to be accessed via address 0x200 to 0x226 (or 0x1E00 to 0x1E26) are specified in 4X Register 0x200 to 0x213. (see TABLE 18)

TABLE 16 : User Assignable 3X Data Registers

Address (Register)	Assignable Register	Modbus Start Address (Hex)	
		High Byte	Low Byte
30513	Assignable Reg 1	02	00
30515	Assignable Reg 2	02	02
30517	Assignable Reg 3	02	04
30519	Assignable Reg 4	02	06
30521	Assignable Reg 5	02	08
30523	Assignable Reg 6	02	0A
30525	Assignable Reg 7	02	0C
30527	Assignable Reg 8	02	0E
30529	Assignable Reg 9	02	10
30531	Assignable Reg 10	02	12

TABLE 16 : Continued...

30533	Assignable Reg 11	02	14
30535	Assignable Reg 12	02	16
30537	Assignable Reg 13	02	18
30539	Assignable Reg 14	02	1A
30541	Assignable Reg 15	02	1C
30543	Assignable Reg 16	02	1E
30545	Assignable Reg 17	02	20
30547	Assignable Reg 18	02	22
30549	Assignable Reg 19	02	24
30551	Assignable Reg 20	02	26

TABLE 17 : User Assignable 4X Data Registers

Address (Register)	Assignable Register	Modbus Start Address (Hex)	
		High Byte	Low Byte
47681	Assignable Reg 1	1E	00
47683	Assignable Reg 2	1E	02
47685	Assignable Reg 3	1E	04

TABLE 17 : Continued...

Address (Register)	Assignable Register	Modbus Start Address (Hex)	
		High Byte	Low Byte
47687	Assignable Reg 4	1E	06
47689	Assignable Reg 5	1E	08
47691	Assignable Reg 6	1E	0A
47693	Assignable Reg 7	1E	0C
47695	Assignable Reg 8	1E	0E
47697	Assignable Reg 9	1E	10
47699	Assignable Reg 10	1E	12
47701	Assignable Reg 11	1E	14
47703	Assignable Reg 12	1E	16
47705	Assignable Reg 13	1E	18
47707	Assignable Reg 14	1E	1A
47709	Assignable Reg 15	1E	1C
47711	Assignable Reg 16	1E	1E
47713	Assignable Reg 17	1E	20
47715	Assignable Reg 18	1E	22
47717	Assignable Reg 19	1E	24
47719	Assignable Reg 20	1E	26

TABLE 18 : User Assignable mapping register (4X registers)

Address (Register)	Mapping Register	Modbus Start Address (Hex)	
		High Byte	Low Byte
40513	Mapped Add for register #0x0200	02	00
40514	Mapped Add for register #0x0202	02	01
40515	Mapped Add for register #0x0204	02	02

TABLE 18 : Continued...

40516	Mapped Add for register #0x0206	02	03
40517	Mapped Add for register #0x0208	02	04
40518	Mapped Add for register #0x020A	02	05
40519	Mapped Add for register #0x020C	02	06
40520	Mapped Add for register #0x020E	02	07
40521	Mapped Add for register #0x0210	02	08
40522	Mapped Add for register #0x0212	02	09
40523	Mapped Add for register #0x0214	02	0A
40524	Mapped Add for register #0x0216	02	0B
40525	Mapped Add for register #0x0218	02	0C
40526	Mapped Add for register #0x021A	02	0D
40527	Mapped Add for register #0x021C	02	0E
40528	Mapped Add for register #0x021E	02	0F
40529	Mapped Add for register #0x0220	02	10
40530	Mapped Add for register #0x0222	02	11
40531	Mapped Add for register #0x0224	02	12
40532	Mapped Add for register #0x0226	02	13

Assigning parameter to User Assignable Registers

To access the Current Ch1 (3X address 0x0002) and Power Ch3 (3X address 0x000E) through user assignable register assign these addresses to 4x register (**TABLE 18**) 0x0200 and 0x0201 respectively.

Assigning Query:

Device Address	01 (Hex)
Function Code	10 (Hex)
Starting Address Hi	02 (Hex)
Starting Address Lo	00 (Hex)
Number of Registers Hi	00 (Hex)*
Number of Registers Lo	02(Hex)*
Byte Count	04 (Hex)

Data Register-1High Byte	00 (Hex)
Data Register-1 Low Byte	02 (Hex)
Data Register-2 High Byte	00 (Hex)
Data Register-2 Low Byte	0E (Hex)
CRC Low	CA (Hex)
CRC High	CB (Hex)

} Current Ch1
(3X Address
0x0002)
} Power Ch3
(3X Address
0x001E)

* Note : Parameters should be assigned in Multiple of two i.e. 2,4,6,8.....20.

Response :

Device Address	01 (Hex)
Function Code	10 (Hex)
Start Address High	02 (Hex)
Start Address Low	00 (Hex)
Number of Registers Hi	00 (Hex)
Number of Registers Lo	02 (Hex)
CRC Low	40 (Hex)
CRC High	70 (Hex)

Reading Parameter data through User Assignable Registers:

In assigning query Current Ch1 & Power Ch3 parameters were assigned to 0x 200 & 0x201 (TABLE 18) which will point to user assignable 3x registers 0x200 and 0x202 (TABLE 16). So to read Current Ch1 and Power Ch3 data reading query should be as below.

Query:

Device Address	01 (Hex)
Function Code	04 (Hex)
Start Address High	02 (Hex)
Start Address Low	00 (Hex)
Number of Registers Hi	00 (Hex)
Number of Registers Lo	04 (Hex)**
CRC Low	F0 (Hex)
CRC High	71 (Hex)

Start Address High : Most significant 8 bits of starting address of User assignable register.

Start Address low :Least significant 8 bits of starting address of User assignable register.

Number of register Hi : Most significant 8 bits of Number of registers requested.
Number of register Lo : Least significant 8 bits of Number of registers requested.

****Note : Two consecutive 16 bit register represent one parameter.
Since two parameters are requested four registers are required**

Response : (A-Ch1 = 219.30 / Power Ch3 = 1.0 W)

Device Address	01 (Hex)
Function Code	04 (Hex)
Byte count	08 (Hex)
Data Register-1 High Byte	43 (Hex)
Data Register-1 Low Byte	5B (Hex)
Data Register-2 High Byte	4E (Hex)
Data Register-2 Low Byte	04 (Hex)
Data Register-3 High Byte	3F (Hex)
Data Register-3 Low Byte	80 (Hex)
Data Register-4 High Byte	00 (Hex)
Data Register-4 Low Byte	00 (Hex)
CRC Low	79 (Hex)
CRC High	3F (Hex)

Current Ch1

Power Ch3

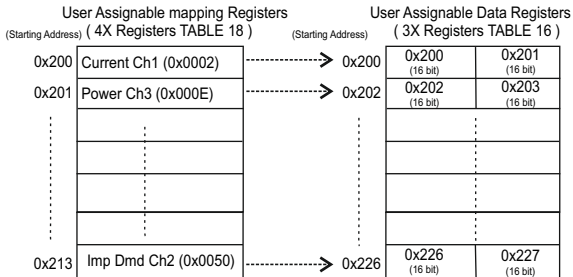

To get the data through User Assignable Register go through the following steps:

- 1) Assign starting addresses (TABLE 1) of parameters of interest to "User assignable mapping registers" in a sequence in which they are to be accessed (see section "Assigning Parameter to User Assignable Registers").
- 2) Once the parameters are mapped, data can be acquired by using "User assignable data register" Starting address i.e. to access data of Current Ch1, Power Ch3, Import Demand Ch2 send query with starting address 0x200 with number of register 8 or individually parameters can be accessed. (See section Reading Parameter data through User Assignable Registers).

4. Datalogging

Datalogging is a feature that allows the meter to store measured parameters based on time or on occurrence of a certain event. The user can retrieve the data later for further application.

This meter offers three types of datalogging

- 1) Event based
- 2) Time based
- 3) Load profile

4.1 Event Based Datalogging

This type of datalogging stores data when certain event is observed. This data is time stamped and last five occurrences of each type of event are stored based on first in first out queue. This meter offers event based logging for 26 parameters. This data can be observed on the modbus on the address table shown below. These registers can be accessed by the query explained in section 3.1 The user can turn this logging on and off through display as well as modbus by using address 40365.

Changing any setup parameter related to the logged parameters will reset the log.

Table 19: 3X addresses for event based datalog

Address	Logged Parameter	Log Details	Mod Start Address Hex	
			High Byte	Low Byte
312289	Max Voltage	Date 1	30	00
312291		Time 1	30	02
312293		Value 1	30	04
312295		Date 2	30	06
312297		Time 2	30	08
312299		Value 2	30	0A
312301		Date 3	30	0C
312303		Time 3	30	0E
312305		Value 3	30	10
312307		Date 4	30	12
312309		Time 4	30	14
312311		Value 4	30	16
312313		Date 5	30	18
312315		Time 5	30	1A
312317		Value 5	30	1C

Address	Logged Parameter	Log Details	Mod Start Address Hex	
			High Byte	Low Byte
312319	Min Voltage	Date 1	30	1E
312321		Time 1	30	20
312323		Value 1	30	22
312325		Date 2	30	24
312327		Time 2	30	26
312329		Value 2	30	28
312331		Date 3	30	2A
312333		Time 3	30	2C
312335		Value 3	30	2E
312337		Date 4	30	30
312339		Time 4	30	32
312341		Value 4	30	34
312343		Date 5	30	36
312345		Time 5	30	38
312347		Value 5	30	3A

Table 19: Continued..

312349	Max Current Ch1	Date 1	30	3C
312351		Time 1	30	3E
312353		Value 1	30	40
312355		Date 2	30	42
312357		Time 2	30	44
312359		Value 2	30	46
312361		Date 3	30	48
312363		Time 3	30	4A
312365		Value 3	30	4C
312367		Date 4	30	4E
312369		Time 4	30	50
312371		Value 4	30	52
312373		Date 5	30	54
312375		Time 5	30	56
312377		Value 5	30	58
312379	Max Current Ch2	Date 1	30	5A
312381		Time 1	30	5C
312383		Value 1	30	5E
312385		Date 2	30	60
312387		Time 2	30	62
312389		Value 2	30	64
312391		Date 3	30	66
312393		Time 3	30	68
312395		Value 3	30	6A
312397		Date 4	30	6C
312399		Time 4	30	6E
312401		Value 4	30	70
312403		Date 5	30	72
312405		Time 5	30	74
312407		Value 5	30	76

312409	Max Current Ch3	Date 1	30	78
312411		Time 1	30	7A
312413		Value 1	30	7C
312415		Date 2	30	7E
312417		Time 2	30	80
312419		Value 2	30	82
312421		Date 3	30	84
312423		Time 3	30	86
312425		Value 3	30	88
312427		Date 4	30	8A
312429		Time 4	30	8C
312431		Value 4	30	8E
312433		Date 5	30	90
312435		Time 5	30	92
312437		Value 5	30	94
312439	Max Current Ch4	Date 1	30	96
312441		Time 1	30	98
312443		Value 1	30	9A
312445		Date 2	30	9C
312447		Time 2	30	9E
312449		Value 2	30	A0
312451		Date 3	30	A2
312453		Time 3	30	A4
312455		Value 3	30	A6
312457		Date 4	30	A8
312459		Time 4	30	AA
312461		Value 4	30	AC
312463		Date 5	30	AE
312465		Time 5	30	B0
312467		Value 5	30	B2

Table 19: Continued..

312469	Min Current Ch1	Date 1	30	B4
312471		Time 1	30	B6
312473		Value 1	30	B8
312475		Date 2	30	BA
312477		Time 2	30	BC
312479		Value 2	30	BE
312481		Date 3	30	C0
312483		Time 3	30	C2
312485		Value 3	30	C4
312487		Date 4	30	C6
312489		Time 4	30	C8
312491		Value 4	30	CA
312493		Date 5	30	CC
312495		Time 5	30	CE
312497		Value 5	30	D0
312499	Min Current Ch2	Date 1	30	D2
312501		Time 1	30	D4
312503		Value 1	30	D6
312505		Date 2	30	D8
312507		Time 2	30	DA
312509		Value 2	30	DC
312511		Date 3	30	DE
312513		Time 3	30	E0
312515		Value 3	30	E2
312517		Date 4	30	E4
312519		Time 4	30	E6
312521		Value 4	30	E8
312523		Date 5	30	EA
312525		Time 5	30	EC
312527		Value 5	30	EE

312529	Min Current Ch3	Date 1	30	F0
312531		Time 1	30	F2
312533		Value 1	30	F4
312535		Date 2	30	F6
312537		Time 2	30	F8
312539		Value 2	30	FA
312541		Date 3	30	FC
312543		Time 3	30	FE
312545		Value 3	31	0
312547		Date 4	31	2
312549		Time 4	31	4
312551		Value 4	31	6
312553		Date 5	31	8
312555		Time 5	31	0A
312557		Value 5	31	0C
312559	Min Current Ch4	Date 1	31	0E
312561		Time 1	31	10
312563		Value 1	31	12
312565		Date 2	31	14
312567		Time 2	31	16
312569		Value 2	31	18
312571		Date 3	31	1A
312573		Time 3	31	1C
312575		Value 3	31	1E
312577		Date 4	31	20
312579		Time 4	31	22
312581		Value 4	31	24
312583		Date 5	31	26
312585		Time 5	31	28
312587		Value 5	31	2A

Table 19: Continued..

312589	Max Imp Power Demand Ch1	Date 1	31	2C	312649	Max Imp Power Demand Ch3	Date 1	31	68
312591		Time 1	31	2E	312651		Time 1	31	6A
312593		Value 1	31	30	312653		Value 1	31	6C
312595		Date 2	31	32	312655		Date 2	31	6E
312597		Time 2	31	34	312657		Time 2	31	70
312599		Value 2	31	36	312659		Value 2	31	72
312601		Date 3	31	38	312661		Date 3	31	74
312603		Time 3	31	3A	312663		Time 3	31	76
312605		Value 3	31	3C	312665		Value 3	31	78
312607		Date 4	31	3E	312667		Date 4	31	7A
312609		Time 4	31	40	312669		Time 4	31	7C
312611		Value 4	31	42	312671		Value 4	31	7E
312613		Date 5	31	44	312673		Date 5	31	80
312615		Time 5	31	46	312675		Time 5	31	82
312617		Value 5	31	48	312677		Value 5	31	84
312619	Max Imp Power Demand Ch2	Date 1	31	4A	312679	Max Imp Power Demand Ch4	Date 1	31	86
312621		Time 1	31	4C	312681		Time 1	31	88
312623		Value 1	31	4E	312683		Value 1	31	8A
312625		Date 2	31	50	312685		Date 2	31	8C
312627		Time 2	31	52	312687		Time 2	31	8E
312629		Value 2	31	54	312689		Value 2	31	90
312631		Date 3	31	56	312691		Date 3	31	92
312633		Time 3	31	58	312693		Time 3	31	94
312635		Value 3	31	5A	312695		Value 3	31	96
312637		Date 4	31	5C	312697		Date 4	31	98
312639		Time 4	31	5E	312699		Time 4	31	9A
312641		Value 4	31	60	312701		Value 4	31	9C
312643		Date 5	31	62	312703		Date 5	31	9E
312645		Time 5	31	64	312705		Time 5	31	A0
312647		Value 5	31	66	312707		Value 5	31	A2

Table 19: Continued..

312709	Max Exp Power Demand Ch1	Date 1	31	A4
312711		Time 1	31	A6
312713		Value 1	31	A8
312715		Date 2	31	AA
312717		Time 2	31	AC
312719		Value 2	31	AE
312721		Date 3	31	B0
312723		Time 3	31	B2
312725		Value 3	31	B4
312727		Date 4	31	B6
312729		Time 4	31	B8
312731		Value 4	31	BA
312733		Date 5	31	BC
312735	Time 5	31	BE	
312737	Value 5	31	C0	
312739	Max Exp Power Demand Ch2	Date 1	31	C2
312741		Time 1	31	C4
312743		Value 1	31	C6
312745		Date 2	31	C8
312747		Time 2	31	CA
312749		Value 2	31	CC
312751		Date 3	31	CE
312753		Time 3	31	D0
312755		Value 3	31	D2
312757		Date 4	31	D4
312759		Time 4	31	D6
312761		Value 4	31	D8
312763		Date 5	31	DA
312765	Time 5	31	DC	
312767	Value 5	31	DE	

312769	Max Exp Power Demand Ch3	Date 1	31	E0
312771		Time 1	31	E2
312773		Value 1	31	E4
312775		Date 2	31	E6
312777		Time 2	31	E8
312779		Value 2	31	EA
312781		Date 3	31	EC
312783		Time 3	31	EE
312785		Value 3	31	F0
312787		Date 4	31	F2
312789		Time 4	31	F4
312791		Value 4	31	F6
312793		Date 5	31	F8
312795	Time 5	31	FA	
312797	Value 5	31	FC	
312799	Max Exp Power Demand Ch4	Date 1	31	FE
312801		Time 1	32	0
312803		Value 1	32	2
312805		Date 2	32	4
312807		Time 2	32	6
312809		Value 2	32	8
312811		Date 3	32	0A
312813		Time 3	32	0C
312815		Value 3	32	0E
312817		Date 4	32	10
312819		Time 4	32	12
312821		Value 4	32	14
312823		Date 5	32	16
312825	Time 5	32	18	
312827	Value 5	32	1A	

Table 19: Continued..

312829	Max Import Current Demand Ch1	Date 1	32	1C
312831		Time 1	32	1E
312833		Value 1	32	20
312835		Date 2	32	22
312837		Time 2	32	24
312839		Value 2	32	26
312841		Date 3	32	28
312843		Time 3	32	2A
312845		Value 3	32	2C
312847		Date 4	32	2E
312849		Time 4	32	30
312851		Value 4	32	32
312853		Date 5	32	34
312855		Time 5	32	36
312857		Value 5	32	38
312859	Max Import Current Demand Ch2	Date 1	32	3A
312861		Time 1	32	3C
312863		Value 1	32	3E
312865		Date 2	32	40
312867		Time 2	32	42
312869		Value 2	32	44
312871		Date 3	32	46
312873		Time 3	32	48
312875		Value 3	32	4A
312877		Date 4	32	4C
312879		Time 4	32	4E
312881		Value 4	32	50
312883		Date 5	32	52
312885		Time 5	32	54
312887		Value 5	32	56

312889	Max Import Current Demand Ch3	Date 1	32	58
312891		Time 1	32	5A
312893		Value 1	32	5C
312895		Date 2	32	5E
312897		Time 2	32	60
312899		Value 2	32	62
312901		Date 3	32	64
312903		Time 3	32	66
312905		Value 3	32	68
312907		Date 4	32	6A
312909		Time 4	32	6C
312911		Value 4	32	6E
312913		Date 5	32	70
312915		Time 5	32	72
312917		Value 5	32	74
312919	Max Import Current Demand Ch4	Date 1	32	76
312921		Time 1	32	78
312923		Value 1	32	7A
312925		Date 2	32	7C
312927		Time 2	32	7E
312929		Value 2	32	80
312931		Date 3	32	82
312933		Time 3	32	84
312935		Value 3	32	86
312937		Date 4	32	88
312939		Time 4	32	8A
312941		Value 4	32	8C
312943		Date 5	32	8E
312945		Time 5	32	90
312947		Value 5	32	92

Table 19: Continued..

312949	Max Export Current Demand Ch1	Date 1	32	94	313009	Max Export Current Demand Ch3	Date 1	32	D0
312951		Time 1	32	96	313011		Time 1	32	D2
312953		Value 1	32	98	313013		Value 1	32	D4
312955		Date 2	32	9A	313015		Date 2	32	D6
312957		Time 2	32	9C	313017		Time 2	32	D8
312959		Value 2	32	9E	313019		Value 2	32	DA
312961		Date 3	32	A0	313021		Date 3	32	DC
312963		Time 3	32	A2	313023		Time 3	32	DE
312965		Value 3	32	A4	313025		Value 3	32	E0
312967		Date 4	32	A6	313027		Date 4	32	E2
312969		Time 4	32	A8	313029		Time 4	32	E4
312971		Value 4	32	AA	313031		Value 4	32	E6
312973		Date 5	32	AC	313033		Date 5	32	E8
312975		Time 5	32	AE	313035		Time 5	32	EA
312977		Value 5	32	B0	313037		Value 5	32	EC
312979	Max Export Current Demand Ch2	Date 1	32	B2	313039	Max Export Current Demand Ch4	Date 1	32	EE
312981		Time 1	32	B4	313041		Time 1	32	F0
312983		Value 1	32	B6	313043		Value 1	32	F2
312985		Date 2	32	B8	313045		Date 2	32	F4
312987		Time 2	32	BA	313047		Time 2	32	F6
312989		Value 2	32	BC	313049		Value 2	32	F8
312991		Date 3	32	BE	313051		Date 3	32	FA
312993		Time 3	32	C0	313053		Time 3	32	FC
312995		Value 3	32	C2	313055		Value 3	32	FE
312997		Date 4	32	C4	313057		Date 4	33	0
312999		Time 4	32	C6	313059		Time 4	33	2
313001		Value 4	32	C8	313061		Value 4	33	4
313003		Date 5	32	CA	313063		Date 5	33	6
313005		Time 5	32	CC	313065		Time 5	33	8
313007		Value 5	32	CE	313067		Value 5	33	0A

4.2 Time Based Datalogging

This type of datalogging stores data with a timestamp at a preset time interval. This can be used to take a snapshot of the system at regular time intervals. This data can be used to do in-depth analysis of the system. The number of parameters to be logged and which parameters to store can also be configured by the user through display as well as modbus. Various configuration registers can be found on addresses 40367 to 40431.

The number of entries stored varies according to the number of parameters logged i.e. more entries can be stored if less number of parameters are being logged. User can configure the meter to store 1 to 30 parameters. And the time interval can vary from 1 to 60 minutes. Editing of these parameters is not allowed while the logging is on.

Each entry consists of number of parameters selected by the user in addition to date and time of the entry log.

Max Memory Locations = 273030

Actual parameters stored in each Entry = Date + Time + User Selected Parameters

Actual parameters count = 1 + 1 + Time Log Parameter Count

Max Entries that can be stored = Max Memory Locations / (Parameter Count + 2)

= 273030 / (Parameter Count + 2)

For example,

Parameter count = 1

Max Entries = 273030 / (1+2)

= 91010

Parameter count = 30

Max Entries = 273056 / (30+2)

= 8532

Interval Setting (min) = 1

Entries in 1 day = (60 / Interval Setting) x 24

= (60 / 1) x 24 = 1440

Max Days = Max Entries / Entries in 1 day

= 8532 / 1440

= 5.92 days

After all memory allocated locations are filled with logging data, the meter will start shifting data by first in first out queue i.e. at any time after all the locations are used once, the user will have access to the latest logged maximum number of entries.

Query Format for Downloading the Time based datalog

The query format for downloading an entry of a time datalog is given below. Maximum number of register the user can access in 1 query are limited by 80 and corresponding to it maximum byte count is 160. The byte count should be logging parameter count multiplied by 4 and added to 8, where 8 is the byte count for date and time (4 bytes x 2 parameters).

(logging parameter count x 4) + (2 x 4)

e.g.
if logging parameter count is 10

byte count = (10 x 4) + 8 = 48 (4 bytes per parameter)

number of registers = (10 x 2) + (2 x 2) = 24 (2 registers per parameter)

Starting address will be 01,CA for time datalog.

The entry number of the desired log need to be converted to IEEE format and sent as 4 bytes.

Query example:

Description	Decimal Value	Hex Value
Dev Addr	3	03
Func Code	16	10
Start Addr Hi		01
Start Addr Lo		CA
No of Reg Hi	00	00
No of Reg Lo	14	0E
Log Download Bytes	28	1C
Entry No Reg 1 Hi	25	41
Entry No Reg 1 Lo		C8
Entry No Reg 2 Hi		00
Entry No Reg 2 Lo		00
CRC Lo		CC
CRC Hi		A4

If a user wants to download 5 parameters logged at entry number 25, the query will be as following (Assuming device address 3). All the data in query is represented in hexadecimal float.

03,10,01,CA,00,0E,1C,41,C8,00,00,CC,A4

03 is device address;
10 is function code;
01 CA is the address that lets the user access the time datalog;
00 0E is number of registers to be accessed (actual parameter count x 2);
1C is number of bytes to be accessed;
41 C8 00 00 is entry number converted to hex;
CCA4 is CRC calculated on query.

Response:

Description	Hex Value	Decimal Value
Dev Addr	03	03
Func Code	10	16
No of bytes	1C	28
Date	46,24,28,00	010506(May 1st 2006)
Time	40,CC,CC,CD	6.40 (06:40 am)
Parameter 1	41,78,1F,68	15.50
Parameter 2	46,AB,5A,12	21933.0
Parameter 3	46,AC,57,6A	22059.7
Parameter 4	46,AB,3C,58	21918.2
Parameter 5	46,A9,AD,9D	21718.8
CRC	BE,7C	

The response to time datalog query contains data in following structure.

First two bytes are device address and function code, followed by number of bytes data of 1 byte and then date and a time data of 4 bytes each.

Then requested parameters are received in order that is specified in timelog parameters settings, each of 4 bytes.

The response ends with 2 bytes of CRC.

4.3 Load Profile Datalogging

This type of datalogging stores data on each day at time 00:00. The parameters stored in this log include energy, maximum power demand and maximum current demand. This log stores data daily as well as monthly interval. Hence, daily and monthly energy consumption for each channel can be logged. Furthermore, maximum power demand and maximum current demand in during each day and each month is also logged for each channel. This data can be used to study load behaviour over a period of time.

The daily data available to the user is maximum of one year interval and the monthly data for 14 years interval assuming the log requested is after the starting date (requesting data before the starting date will result in modbus exception message). 1 year after the starting date, the oldest logs of daily data are constantly replaced with latest logs. 14 years after the starting date, all the load profile logs for that channel are cleared and logging is started again.

This log can be selected or de-selected for individual channel i.e. if a channel is selected to be load profile logged; energy, maximum power demand and maximum current demand on that channel will be logged. The starting date of this datalog for each channel is stored in read only memory locations 40435 to 40441.

The user can access different parameters in this log this log by sending queries using following addresses.

Note: Changing the meter date resets the load profile log.

Table 20: Addresses for Load Profile datalog access

Parameter	Modbus Start Address Hex	
	High Byte	Low Byte
Daily Energy Datalog Download Addr	01	CC
Daily Maximum Power Demand Datalog Download Addr	01	CE
Daily Maximum Current Demand Datalog Download Addr	01	D0
Monthly Energy Datalog Download Addr	01	D2
Monthly Maximum Power Demand Datalog Download Addr	01	D4
Monthly Maximum Current Demand Datalog Download Addr	01	D6

Query Format for Downloading the Load Profile Datalog

The query format for downloading an entry of a daily load profile log is given below. Maximum number of register the user can access in 1 query are limited by 80.

Query example:

Description	Decimal Value	Hex Value
Dev Addr	03	03
Func Code	16	10
Start Addr Hi		01
Start Addr Lo		CC
No of Reg Hi	00	00
No of Reg Lo	20	14
Log Download Bytes	40	28
Parameter no	03	03
Date	04	04
Month	11	0B
Year	14	0E
CRC Lo		AD
CRC Hi		C3

Example: If a user wants to access daily energy load profile log of channel 3 for 10 days from 4 November 2014 to 13 November 2014, the query for this will be as following.

03,10,01,CC,00,14,28,03,04,0B,0E,AD,C3

03 is device address;

10 is function code;

01 CC is the starting address for accessing the daily energy load profile log. (refer table 20)

00 14 is the number of registers to be accessed. This value will be double of the number of parameters requested.

28 is the number of bytes requested in this query. This value will be 4 times the number of parameters requested.

03 is the parameter number for channel 3 import data. (refer table 21)

04 0B 0E is the starting date of the log to be accessed.

AD C3 is the CRC added at the end.

Table 21: Parameter number for Load Profile

Para No.	Description
1	Import Ch1
2	Import Ch2
3	Import Ch3
4	Import Ch4
5	Export Ch1
6	Export Ch2
7	Export Ch3
8	Export Ch4

The load profile datalog access query consists of device address and function code followed by the starting address which is different for different parameters and mentioned in Table 20. Number of registers can vary in multiple of 2, but can not exceed 80 and corresponding to it, number of bytes can not exceed 160.

Parameter number decides the parameter within the log (eg. channel 2 export energy from the daily energy log.) Refer Table 21.

Date, month and year decides the date from which the data is to be downloaded.

All data in the query is represented in hexadecimal format.

At the end 2 byte CRC is calculated.

Response:

Description	Hex	Decimal
Dev Addr	03	03
Func Code	10	16
Number of bytes	28	40
Value 1 (Nov 4)	48,6A,B4,80	240338
Value 2 (Nov 5)	48,6A,AD,40	240309
Value 3 (Nov 6)	48,6A,AA,C0	240299
Value 4 (Nov 7)	48,6A,B6,40	240345
Value 5 (Nov 8)	48,6A,B1,40	240325
Value 6 (Nov 9)	48,6A,B4,80	240338
Value 7 (Nov 10)	48,6A,B7,40	240349
Value 8 (Nov 11)	48,6A,AF,C0	240319
Value 9 (Nov 12)	48,6A,B3,40	240333
Value 10 (Nov 13)	48,6A,BD,C0	240375
CRC	A9,2A	

The response to the load profile query contains device address, function code and number of bytes data each of 1 byte, and then the requested parameters of 4 bytes each. Each parameter represents data over a period of a day when daily log is accessed and represents data over a period of a month when monthly log is accessed.

The response ends with 2 byte CRC.

Note: If a user tries to access the data which is out of the range of the datalog i.e. more than 1 year before the present date for daily log and more than 14 years before the present date for monthly log, it will result in a modbus exception. The same will occur if a user tries to access the data before the starting date of the corresponding log or a future date.

5. Connection for Optional Pulse Output / RS 485 (rear view of Multifunction Meter):

1. RS 485 Output

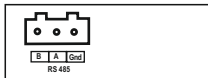

2. Relay1 & Relay2

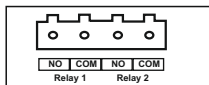

3. Relay1, Relay2, Relay3, Relay4

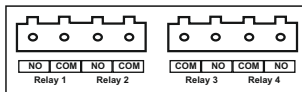

4. RS 485 Output with Relay1 & Relay2

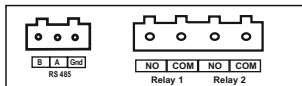

5. USB and RS 485

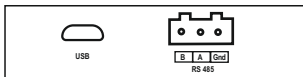

6. USB and Relay1 & Relay2

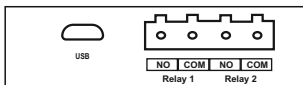

7. USB and Relay1, Relay2, Relay3, Relay4

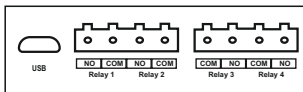

8. USB and RS 485 Output with Relay1 & Relay2

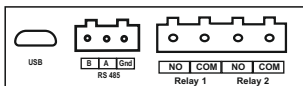

9. RS 485 Output with Relay1, Relay2, Relay3, Relay4

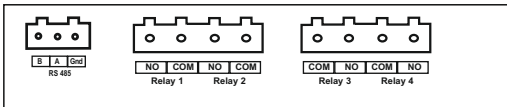

10. USB and RS 485 Output with Relay1, Relay2, Relay3, Relay4

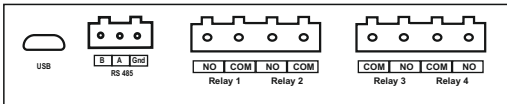

Contact



Sifam Tinsley Instrumentation Ltd

1 Warner Drive
Springwood Industrial Estate Braintree
Essex
CM7 2YW

Tel: 01376 335271
Email: sales@sifamtinsley.com

www.sifamtinsley.co.uk

The Information contained in these installation instructions is for use only by installers trained to make electrical power installations and is intended to describe the correct method of installation for this product. However, 'manufacturer' has no control over the field conditions which influence product installation.

It is the user's responsibility to determine the suitability of the installation method in the user's field conditions. 'manufacturer' only obligations are responsibility to determine the suitability of the installation method in the user's field conditions. 'manufacturer' only obligations are those in 'manufacturer' standard Conditions of Sale for this product and in no case will 'manufacturer' be liable for any other incidental, indirect or consequential damages arising from the use or misuse of the products.