



DATASHEET

Issue 1



Multifunction Meters

Transducers & Isolators

Temperature Controllers

Converters & Recorders

Digital Panel Meters

Current Transformers

Analogue Panel Meters

Shunts

Digital Multimeters

Clamp Meters

Insulation Testers

EM DC 6001-6002 COMPACT DC ENERGY METER

Product Characteristics

- Multi-channel support
- RTC with Data Storage
- RS485 Output
- Isolated Voltage Channel
- Alarming & Protection
- Onsite Programmable
- Load Profile Analysis

SUBJECT TO CHANGE WITHOUT NOTICE

This datasheet superseded all previous versions – please keep for future reference

Applications

- Solar Photovoltaic Systems
- Battery chargers and systems
- Wind Power Generation
- Electroplating Industries
- Power Distribution for Telecommunication
- Industrial DC control Systems

Possible Applications of Relay Outputs

- Alarming via lamp or horn
- Load shedding
- Remote controlling

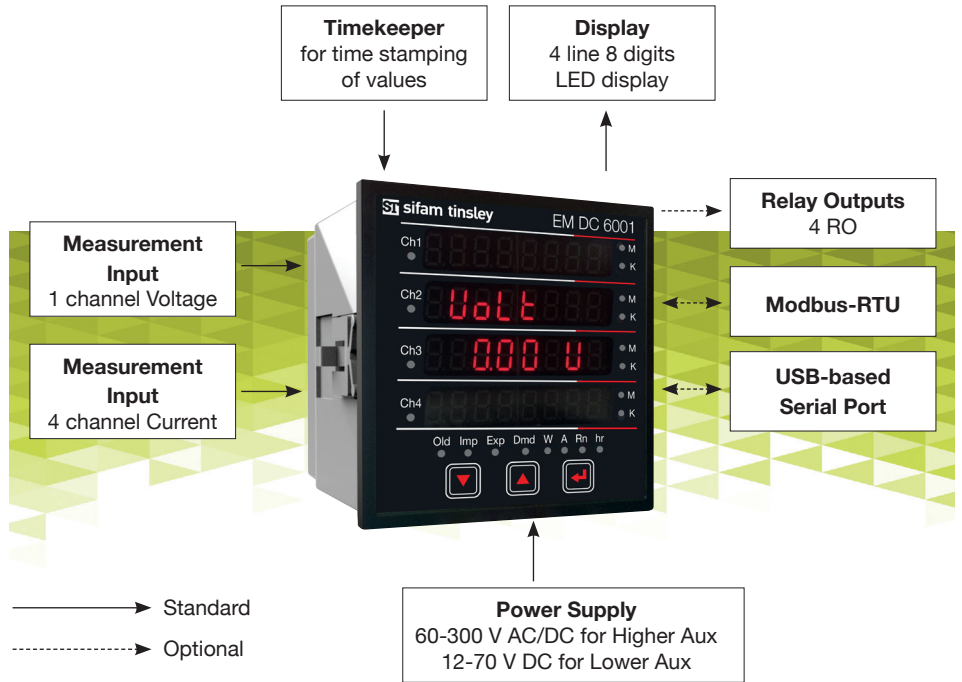

—————> Standard
 - - - - -> Optional

Product Features

Multi-Channel Support

- Single meter measures energy consumption of four independent loads connected to one Voltage source

Bi-Directional Voltage & Current measurement

- The meter has a unique feature of measuring both charging and discharging current.

Isolated Voltage Channel

- The Voltage channel is galvanically isolated from rest of the circuitry.

Event Logging

- Previous 5 Events of factory-default parameters can be logged with Date and Time stamp.

Data Logging

- User Selectable parameters (1 to 30) can be logged at regular intervals (1 to 60 min) with Date & Time stamp in internal memory and can be accessed via Modbus.
- Max Records can vary from 8532 to 91010 depending upon number of selected parameters.

Load Profile Analysis

- Logging of Energy consumed and Peak Demand (Power & Current) in a day and in a month for efficient tracking of load behaviour.
- Daily Data is available for last 1 year and Monthly Data is available for last 14 years.

Direct Remote Access (optional)

- Remote configuration of the Instrument and access of measured parameters via MODBUS.
- Programmable baud rates up to 57.6kbps.

4 - line 8 digit Ultra-bright LED Display

- 4 - line LED display provides easily readable data on meter front with a display range of 99999999.

Reverse Locking

- Energy and Ampere Hour accumulation can be blocked for Reverse Power and Current resp.
- Reverse condition can be set as Import or Export.

Onsite Configuration

- Configuration can be done via Front Keys, USB Serial Interface or RS485 (MODBUS).

Relay Functions

- Limit Switch - For protection against over shoot or under-shoot of any selected parameter
- Pulse Output - To drive an external counter for energy measurement
- Timer - Cyclic ON-OFF operation of relay for user-defined cycles with programmable ON-OFF Delays
- Remote Operation - Relays can be activated remotely via Modbus
- Reverse Locking Alarm
- RTC Relay - Relay can be activated & deactivated at predefined ON & OFF Time on any or all Days of Week

Enclosure Protection for dust and water

- Conforms to IP 54 (front face) as per IEC60529

Compliance to International Safety standards

- Compliance to International Safety standard IEC 61010 - 1-2010

EMC Compatibility

- Compliance to International standard IEC 61326 - 2012

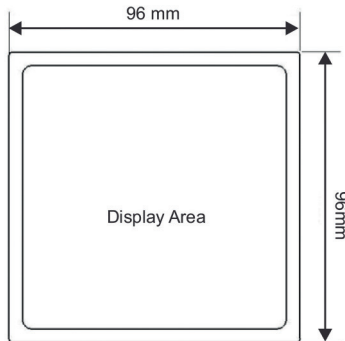
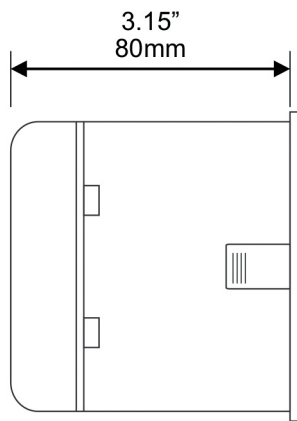
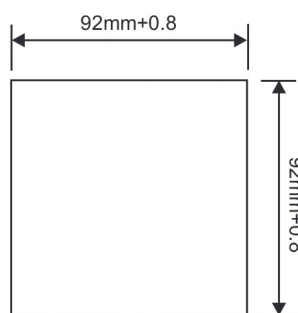
Dimensions Details

Front View

Side View

Panel Cutout
Technical Specifications

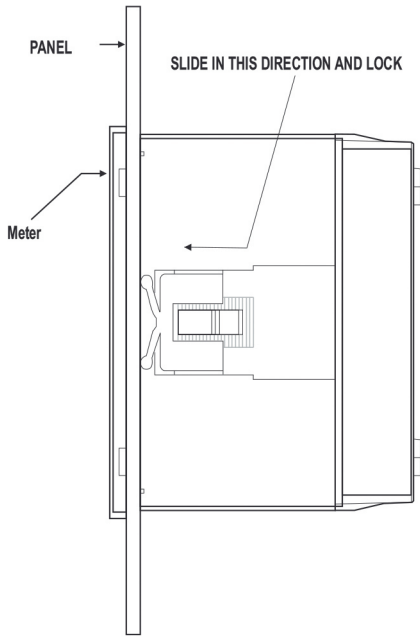
Input Voltage	
Nominal Input Voltage Range	10 ~ 60 VDC 61 ~ 200 VDC 201 ~ 1000 VDC
Max continuous input voltage	125% of nominal value
Input Current	
No of Channels	4
Current Sensor	External Shunt
Shunt Setting Range	50 ~ 150 mV
Full Scale Setting Range	1 A to 20 kA
Max continuous input current	125% of nominal value
Operating Measuring Range	
Voltage	± 2 to $\pm 125\%$ of nominal value
Current	± 0.2 to $\pm 125\%$ of nominal value
Auxiliary Supply	
Higher Aux	60 V – 300 V AC-DC, 45 to 65 Hz range
Lower Aux	12 V – 70 V DC
Nominal Value	230 V AC-DC, 50/60 Hz for Higher Aux 24 V DC for Lower Aux
VA Burden	
Nominal input voltage burden	< 0.4 W approx.
Nominal input current burden	< 0.1 W approx. per channel
Auxiliary Supply burden	< 6 VA approx
Accuracy	
Reference Conditions	23°C +/- 2°C
Voltage	$\pm 0.5\%$ of Nominal value (± 5 to $\pm 120\%$)
Current	$\pm 0.5\%$ of Nominal value (± 5 to $\pm 120\%$)
Power	$\pm 0.5\%$ of Nominal value (± 5 to $\pm 120\%$)
Energy	Class 1
Temperature Drift	0.1%/°C
Display	
Type	4 line 8-digit LED Display
Display Height	9 mm
Overload Indication	-oL- (Above 126% of nominal value)
Display Range	
Voltage	0 to ± 9999
Current	0 to ± 9999
Power	0 to ± 9999
Energy (Import & Export)	0 to 99999999
Relay Output	
Max Load Voltage	250 VAC / 30 VDC
Max Load Current	5 A
Real Time Clock (RTC)	
Uncertainty	± 2 minutes / month (23°C +/- 2°C)

NOTE: Variation due to influence Quantity is 100% of class index

Installation



Electrical Connection

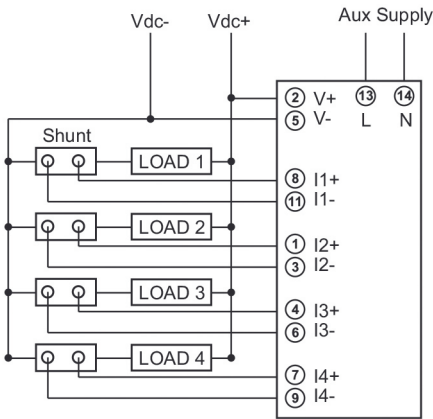

Technical Specifications

Optional RS485 Communication	
Protocol	Modbus-RTU
Baud rate	4800, 9600, 19200, 38400, 57600 bps
Distance	1200 m
Overload Withstand	
Voltage	2 x rated value for 1 second, repeated 10 times at 10 second intervals
Current	20x rated value for 1 second, repeated 5 times at 5 min intervals
Applicable Standards	
EMC	IEC 61326-2012
Immunity	IEC 61000-4-3. 10V/m min – Level 3 industrial Low level
Safety	IEC 61010-1-2010 , Permanently connected use
IP for water & dust	IEC 60529 (IP 54)
Pollution degree	2
Installation category	1000V CATII, 600V CATIII (Measuring Inputs) 300V CATIII (Power Supply)
Protective Class	2
High Voltage Test (DC, 1 minute)	6.22 kV DC, Enclosure versus all electrical circuits 5.23 kV DC, Auxiliary Supply versus all other electrical circuits 3.11 kV DC, Measuring Terminals versus all other electrical circuits 3.11 kV DC, Relay versus Relay 3.11 kV DC, USB & RS485 versus all other electrical circuits 3.11 kV DC, Voltage versus Current
(Optional)	
Environmental	
Operating temperature	-10 to +55°C
Storage temperature	-20 to +70°C
Relative humidity	0... 90% non condensing
Warm up time	Minimum 3 minute
Shock	15g in 3 planes
Vibration	10... 55...10 Hz, 0.15mm amplitude
Number of Sweep Cycles	10 per axis
Dimensions & Weights	
Bezel Size	96 mm x 96 mm DIN 43 718
Panel Cut-out	92 + 0.8 mm x 92 + 0.8 mm
Overall Depth	80 mm
Weight	620 gm. approx.

It is recommended that the wires used for connections to the instrument should have lugs soldered at the end. That is, the connections should be made with Lugged wires for secure connections. The Maximum diameter of the lug should be 7.0 mm and maximum thickness 3.5mm. Permissible cross section of the connections wires: <= 4.0 mm sq. single wire or 2x2.5mm sq. fine wire.

Measured Parameters

Sr No	Parameters	Sr No	Parameters
1	Voltage	41	Max Import and Export Power Demand channel 1
2	Current channel 1	42	Max Import and Export Power Demand channel 2
3	Current channel 2	43	Max Import and Export Power Demand channel 3
4	Current channel 3	44	Max Import and Export Power Demand channel 4
5	Current channel 4	45	Max Import and Export Current Demand channel 1
6	Total Import & Export Power	46	Max Import and Export Current Demand channel 2
7	Power channel 1	47	Max Import and Export Current Demand channel 3
8	Power channel 2	48	Max Import and Export Current Demand channel 4
9	Power channel 3	49	Number of Interruptions
10	Power channel 4	50	Old Import and Export Energy channel 1
11	Total Import & Export Energy	51	Old Import and Export Energy channel 2
12	Import and Export Energy channel 1	52	Old Import and Export Energy channel 3
13	Import and Export Energy channel 2	53	Old Import and Export Energy channel 4
14	Import and Export Energy channel 3	54	Old Import and Export Ampere Hour channel 1
15	Import and Export Energy channel 4	55	Old Import and Export Ampere Hour channel 2
16	Total Import & Export Ampere Hour	56	Old Import and Export Ampere Hour channel 3
17	Import and Export Ampere Hour channel 1	57	Old Import and Export Ampere Hour channel 4
18	Import and Export Ampere Hour channel 2	58	Old Max Import and Export Power Demand channel 1
19	Import and Export Ampere Hour channel 3	59	Old Max Import and Export Power Demand channel 2
20	Import and Export Ampere Hour channel 4	60	Old Max Import and Export Power Demand channel 3
21	Total Import & Export Power Demand	61	Old Max Import and Export Power Demand channel 4
22	Import and Export Power Demand channel 1	62	Old Max Import and Export Current Demand channel 1
23	Import and Export Power Demand channel 2	63	Old Max Import and Export Current Demand channel 2
24	Import and Export Power Demand channel 3	64	Old Max Import and Export Current Demand channel 3
25	Import and Export Power Demand channel 4	65	Old Max Import and Export Current Demand channel 4
26	Total Import & Export Current Demand	66	Old On Hour
27	Import and Export CurrentDemand channel 1	67	Old Run Hour channel 1
28	Import and Export CurrentDemand channel 2	68	Old Run Hour channel 2
29	Import and Export CurrentDemand channel 3	69	Old Run Hour channel 3
30	Import and Export CurrentDemand channel 4	70	Old Run Hour channel 4
31	On Hour	71	Old Number of Interruptions
32	Run Hour channel 1		
33	Run Hour channel 2		
34	Run Hour channel 3		
35	Run Hour channel 4		
36	Max and Min Voltage		
37	Max and Min Current channel 1		
38	Max and Min Current channel 2		
39	Max and Min Current channel 3		
40	Max and Min Current channel 4		

Ordering Information

Ordering information	Ordering Code
Model	EM DC
Basic Model (without USB, RTC & Datalogging)	6001
Higher Model (with USB, RTC & Datalogging)	6002
Nominal Input Voltage	
10 - 60 V	60
61 - 200 V	200
201 - 1000 V	1000
Auxiliary Supply Voltage	
60 - 300 V AC DC	HA
12 - 70 V DC	LA
Communication	
MODBUS (RS485)	C
MODBUS Option not used	NC
Output Options	
No Relay Output	NR
2 Relay Outputs	2R
4 Relay Outputs	4R

Order Code Example:
EM DC - 6002 - 60 - HA - C - 2

EM DC Higher Model, Voltage Range 10 - 60 V, Higher external aux 60V – 300V AC/DC, with MODBUS (RS485) communication, 2 relay outputs.

Contact

Sifam Tinsley Instrumentation Ltd

 1 Warner Drive
 Springwood Industrial Estate
 Braintree
 Essex
 CM7 2YW

 Tel: 01376 335271
 Email: sales@sifamtinsley.com

www.sifamtinsley.co.uk